



2022 New London-Waterford Speedbowl Truck Division Rules (Last Updated: **2-22-22**)

Changes from the 2021 rulebook have been highlighted in red.

NLWS Truck Division Competition and Tech Contacts:

*Eric Webster - New London-Waterford Speedbowl
Saturday NLWS Race Director
Email: Webby@speedbowlct.com*

Joseph Delorimiere – New London Waterford Speedbowl
Truck Division Technical Inspector
Email: grip340@aol.com - Phone: 860-514-1713

All references to the New London-Waterford Speedbowl in the following rules may be referred to as (NLWS) as an abbreviation of the speedway name and deemed an official recognition of the New London -Waterford Speedbowl in this 2022 rulebook.

Drivers & Car Owners are required to familiarize one's self with the General Track Rules as well as the Truck Division rulebook.

By registering as an owner or driver you agree to be knowledgeable and bound by the contents found in these divisional rules and in the General Rules.



Drivers & Car Owners are required to familiarize one's self with the General Track Rules as well as the NLWSB Truck division rule book.

By registering as an owner or driver you agree to be knowledgeable and bound by the contents found in these divisional rules and in the General Rules.

All New London Waterford Speedbowl Trucks are required to utilize Scoring Transponders. More information is contained inside this rulebook

The only race trucks allowed to compete in the NLWS Truck Division will be based off of the 108" wheelbase GM G-Metric Chassis. New trucks may be built using the illustrations contained within these rules so long as it is constructed on an unaltered 1978 to 1987 GM G-Metric Chassis or similar aftermarket tubular chassis (ex. Johnson Chassis, Hamm Chassis, etc.) that maintains factory dimensions, pick-up points, etc.

1.0 General NLWS Truck Division Rules

1. Any competitor who has previously participated in any sanctioned racing division is eligible to compete in any NLWS Truck event without specific approval from the New London-Waterford Speedbowl. Driver eligibility is the decision of the track officials.
2. In the following rules you will see the term "stock OEM" used. This means "original equipment manufacturer". These parts must come on your standard production car.
3. No carbon fiber or titanium parts allowed unless specified.
4. None of the following will be allowed in or on any engine or driveline component or part: abrasive cleaning, acid dipping, chemical milling, coating, epoxying finishing, grinding, painting, plating, polishing, porting, etc.
5. The rules herein are for the New London-Waterford Speedbowl only, with no expressed or implied agreement with any other division or speedway as to their interpretation and/or method of inspection.
6. All equipment must be approved by track officials. No equipment is considered to be approved by reason of having passed through a technical or safety inspection unobserved. No truck will be considered as having passed inspection for the event until the finish is made official.
7. All engine models, equipment changes, or modifications not specifically addressed in this rule book must be submitted in writing to the New London-Waterford Speedbowl for consideration and approval prior to competition.
8. All equipment is subject to the approval of the New London-Waterford Speedbowl Officials.
9. Once a car has been presented to the New London-Waterford Speedbowl Officials for pre-race or post-race inspection the entire car and all of its components become subject to inspection. This includes but is not limited to items verbally designated for inspection before or following a particular event
10. All rule changes and updates made during the course of the season to the current rulebook will be posted to

the New London-Waterford Speedbowl website (www.speedbowl.com). This will serve as the only form of official notification until the posting of the **2023** New London-Waterford Speedbowl rulebook on the NLWS website.

11. Safety Equipment:

A. Helmets: SA2005, SA2010 or SA2015 rated full-face helmets are mandatory for all motor vehicle events. The helmet and a face shield or other acceptable eye protection must be worn at all times during any event.

B. Seatbelts: Each car must be equipped with an SFI rated and approved 5 or 6-point seat belt system. The belt latching mechanism must provide a common connection and release for the lap belts, shoulder belts, and the anti-submarine (crotch) belt(s). The seat belts must be installed in accordance with the directions provided by the belt supplier and/or manufacturer. The belts must be bolted to the roll cage/frame using the appropriate diameter Grade 8 bolts, washers, and locknuts. Where the shoulder harness lays across your shoulders, it must pass over a bar located at shoulder height, and the belts must pass through the cut-out in the seat without contacting the seat cut-out. Date stamps must be visible and must indicate that all belts are no more than 3 years old.

Please refer to the following information regarding seat belt installation:

http://www.circletrack.com/safety/ctrp_0712_seat_harness_mount/index.html

C. Seats: Each car must be equipped with a commercially manufactured aluminum oval track racing seat. The seat must be securely and professionally mounted to the roll cage, utilizing **minimum** 3/8" diameter Grade 8 bolts, washers, and locknuts. The seat must be installed in a steel frame that is welded to the roll cage structure. It cannot be attached to the floorboard. The installation of the seat must be acceptable to track officials. All seats are required to have commercially manufactured and padded head supports, shoulder supports, and leg supports (2 of each). The 6 supports must be installed in accordance with the directions provided by the supplier and/or manufacturer.

D. Window Nets: An SFI rated nylon window net must be installed in the left side door window opening. It must be positioned to cover the driver. The window net must be rib type, made from 3/4" or 1" wide nylon material with a minimum 1" and a maximum of 2-1/4" square opening between the ribs. The minimum window net size is approximately 22" wide by 16" high. All window net mounts must be a minimum 1/2" diameter solid steel rod on the bottom and a minimum 1" wide by 3/16" thick flat steel bar, or a minimum 1/2" diameter solid steel round bar on the top, with mounts welded to the roll cage. The window net, when in the closed position, must fit tight and be secured with a lever-type quick release latch acceptable to Track Officials. The lever must be secured by a detent ball in the lever and may be supplemented by a Velcro® fastener only – pins or clips will not be permitted. The latch must mount at the top in the front to roof bar (#3) and release from the inside. Date stamps must be visible and must indicate that the net is not more than 3 years old.

E. Fire Safety: Each truck must have an approved fire extinguisher or FireBottle type suppression system installed for the driver's safety. All extinguishers and systems must be securely and mechanically fastened, and be fully functional and operational. The fire extinguisher or system must be of an approved class of 1301 Halon or equivalent.

F. Fire Suits: Each driver must wear an SFI rated and approved fire suit, and should wear SFI approved undergarments, including a top, bottom, and socks.

G. Gloves and Shoes: SFI approved fire retardant racing gloves and shoes are mandatory.

12. Drivers 14 years old and up are eligible to compete in the New London Waterford Speedbowl Truck Division.

13. In order to participate in any on-track activity, a driver must be signed in with the handicapper **and have all completed**

paperwork on file. Paperwork includes Driver Registration form, Number Registration Form, etc.

14. Spotters: Spotters are mandatory. All spotters must report to the Spotters Pen located in the Main Grandstands under the scoring tower prior to ALL races. All spotters must check in with the official in the pen. All spotters must be able to be identified by the Pen Official. If a truck does not have a spotter in the spotters' pen, the truck may not be scored and/or may be removed from the racing surface.

15. Transponder Location: Transponder mounting brackets will be installed on the inside (or outside) of the right rear frame rail. The round post of the bracket must be on top and the square tab on the bottom flush with the lower edge of the frame rail. The bracket must be mounted with its center line exactly 12" to the rear of the rear axle centerline and must be completely vertical to the ground. Transponders are required on the trucks at all times. Any truck not registering a transponder signal during practice may be black-flagged to be made aware of their scoring transponders failure and is required to remedy it before proceeding further in the event.

Transponders are available from: AMB, US, Inc. 32 Highlands Parkway, Suite 104 Smyrna, GA 30082 Tel 678-816-4000 Fax 678-816-4001

1.1 Approved Chassis

1. Open to most any racetrucks based off of the GM "G" Metric Chassis. Trucks may be from the old American Race Truck Series, Allstar Race Truck Series, New England Truck Series or similar. New trucks can be constructed using the Johnson X-Y-Z "G" Metric Chassis using Appendix B. Beginning in 2021 Any truck that meets the current year Seekonk Sport Truck Rules is allowed to compete in the NLWS Truck Division. See below for specific rules.

2. The only approved frame is the General Motors 1978 to 1987, "G" body, 108.1", metric-frame. All measurements, lines, holes, etc., must retain the manufacturer's specifications. Design and construction of roll cage and chassis must be as shown in either Appendix A or as shown on Appendix B. Must be one or the other, no converging the two designs.

3. Chassis height for all trucks is a minimum of 5 inches in race-ready condition with the driver seated in the seat and measured at any location on the chassis. No ballast lead may be lower than the 5" chassis Height.

4. No plating of the frame. Boxing the C-channel is permitted. Rear spring and shock perches must remain in factory location. Lower and upper trailing arm mounting brackets must remain in factory location and configuration. Rear cross member must remain in factory location. A four-inch-tall by six-inch O.D spring bucket may be installed to raise original spring pocket. Spring bucket must remain in original stock factory location. Rear shocks must be mounted in their original location. (See Appendix A or Appendix B)

5. 2" x 3" rectangular steel tubing (minimum .083", maximum .125") may be used to replace the rear frame horns from the back side of the spring pocket perch (not the spring bucket), to the back side of the stock frame.

6. The Johnson and Hamm's "X-Y-G Metric" Chassis and Front Clip is allowed. The chassis and the Front Clip must remain as manufactured and retain all factory OEM Specs including but not limited to Upper and Lower A-Frame Locations, Steering Component Locations, Shock Locations, Rear Trailing Arm Locations, and Engine Mounting Locations. The Johnson Stock Replacement Lower A-Frame or equivalent is approved for use.

7. Any tubing must maintain a minimum ground clearance of 6", measured from the bottom of the tubing to the ground.

8. No cutting or welding to alter the wheelbase. Chassis/frame must remain square to factory specifications

measurements.

9. Appendix A design chassis, the passenger side door bars may be X member instead of 4 bars. Must be constructed of no less than 1.75" O.D. x .095" Wall round tubing.

10. All Non-A.R.T.S. style serialized chassis must have pre-approval from New London Waterford Speedbowl before it is permitted to compete. It is the driver's responsibility to have the chassis/truck inspected prior to racing if it is not one of the above listed approved types of trucks.

11. Only trucks determined to meet the applicable specifications are eligible to compete in the NLWS Truck Division. You must contact the New London-Waterford Speedbowl to find out if your truck is eligible for competition if it does not fit into the above listed guidelines.

1.2 Truck Body Requirements

APPROVED TRUCK BODY MANUFACTURERS: Any commercially produced Race Truck Body is permitted so long as it is Fiberglass and/or Aluminum. No Magnetic Steel Side Panels allowed. AR Race Car bodies, Speedway Racing Bodies, Five Star Race Car Bodies, Lightning Light, Performance Fiberglass Products and Haltin Bodies.: 1997 through the current year Chevrolet Silverado, 1997 through 2016 Ford F-150, 1997 through the current year Dodge Ram and Toyota Tundra, 2008 through the current year. Doors and rear quarter panels may be fabricated from aluminum sheet of the same thickness as the manufacturer uses. Any fabricated panels must have body lines similar to original manufacture.

- 1.** Dimensions of all bodies must remain as manufactured except for changes needed for tire clearance and/or to fit the 108-inch wheelbase.
- 2.** No carbon fiber bodies or carbon fiber body components permitted.
- 3.** Nose piece and tailgate may be polypropylene plastic or fiberglass. Note: Bed lids may be fiberglass, sheet metal, or aluminum.
- 4.** Truck bodies must present a neat, positive, professional image. Any damage incurred must be repaired prior to the next scheduled race event. Appearance standards are at the discretion of the NLWS Track Officials.
- 5.** All trucks must be neatly painted and lettered. Numbers must be at least 18" high on both doors and roof. Numbers must be clearly readable from the scorers' booth. No Three-digit Numbers and/or Letters permitted.
- 6.** Minimum roof height must be 55" inches measured 10" back from leading edge of roof.
- 7.** Minimum side window opening must be at least 17 inches.
- 8.** A nylon window net must be installed in the left side door window opening and be positioned to cover the entire window opening. (See illustration 1)
- 9.** Windshield angle (checked at center of windshield) must be no less than 37 degrees with truck in race-ready condition.
- 10.** The windshield and rear window must be bolted or riveted in along all four sides. You may not use side

windows. Windshield must be supported in center top to bottom and braced to the windshield bar.

11. Bodywork must maintain original manufacturer's configuration, size and shape must adhere to body diagram.

12. Front and rear window openings must be covered with 0.125-inch clear Lexan. Lexan must cover entire opening and should follow the contours of the body.

13. Lexan side window vents are optional but cannot exceed 12 inches in length from leading edge of the window opening.

14. Any hood may be used so long as the hood completely covers the engine compartment and Air Cleaner, except where specified in rule 1.6.1 Air Cleaners, Section 4.

15. Hoods must have positive fasteners installed, a minimum of 4 (four) hood pins. Dzus Buttons are not allowed to hold down the hood. Hood must fit flat to fenders. Hood may have maximum gap of 1-inch between windshield and back of hood as measured following the horizontal plane of the hood to windshield.

16. Maximum rear deck height is 40". No Tolerance will be allowed.

17. Full rear deck lids are mandatory. The rear half of the lid must be able to open for inspection purposes. Rear deck lid must completely cover the rear of the body. No openings in rear or any other area to release air is permitted. Rear deck lid must be solid, no holes, louvers, etc.

18. Positive fasteners must be used on the left and right side to secure opening position of the rear deck lid. Dzus Buttons are not allowed to secure the rear deck lid.

19. Front air dams must maintain their original configuration. All body support brackets must be located inside the body structure.

20. A non-adjustable rear spoiler is mandatory. Spoiler may be made of metal or 1/8-inch-thick Lexan. Spoiler may have a 1/2 inch break at the top as long as the break is going away from the truck.

21. The spoiler may be no larger than 10" tall and no wider width of the rear deck. Spoiler braces may be used on rear of spoiler only. Any part of the spoiler higher than 6" must be clear Lexan.

22. An aftermarket tube bumper must be used or you may fabricate your bumpers. Front Bumpers may be made of no larger than 1 3/4 "round tube and must follow the contour of the bumper cover. Rear bumpers may be no larger than 2"x3" Box Tubing or similar, a single aluminum modified racecar type bumper may be used as the rear bumper. Front bumpers may be 2 tubes, stacked and welded together. Bumper ends must be capped. You may not compete without a securely, mechanically fastened front and rear bumper. Bumpers and bumper mounts may not be overly reinforced. Bumper and Bumper Mounting approval is at the discretion of New London-Waterford Speedbowl Officials.

23. Polycarbonate rub rails are allowed and are the only type permitted outside of the body. Any rub rails or steel, aluminum, or other material that NLWS Officials deem to be a "Rub Rail" must be removed by the competitor when requested. Any excessive reinforcement behind any body panels as deemed by NLWS Officials will not be permitted.

24. One rear view mirror is allowed. The addition of a one (1) 3" diameter maximum spot mirror is permitted.

25. The front firewall must completely seal the driver's compartment from the engine compartment. The rear firewall must completely seal the driver's compartment from the fuel cell/trunk area. All holes in either firewall must be suitably covered with a minimum of .024" / 24 gauge magnetic steel.

1.3 Truck Weights and Chassis Heights

1. Minimum weight may be taken with driver pre and/or post-race.

2. Weights are as listed below:

A- Unaltered GM **NLWS or Thompson Speedway Sealed** "602" Crate Engine as listed in rule 1.5 is 2850lbs.

B- GM 305, Ford 302, Dodge 318 "Open Motor" is 2850lbs.

C- SK Lite **Stafford Motor Speedway Rules** "602" Crate Engine is 2950lbs. **See Section 1.4 Section 2.**

D- 350 Chevrolet Sportsman/Truck engine is 2950lbs. See Section 1.5 Section 4.

E-Seekonk Sport Trucks must weight 2950lbs.

F.-Trucks running a 3-Link Rear Suspension MUST ADD 50LBS to the total weight listed above.

2. Left Side Weight Maximum is 56%

3. All weights will be checked with the driver in the seat, helmet on the head, both hands on the steering wheel, feet on the pedals, and the driver in an upright position.

4. All added weight must be in block form. No weight may be placed in the driver's compartment. ALL Ballast weight must be encased in steel tubing with .125 minimum wall thickness bolted with a minimum of two ½" diameter grade 8 bolts. Any truck with improperly mounted weight will not be allowed to compete. No weight shall be lower than the frame where it is attached. All added weight must be painted white and have the number of the truck clearly marked on the weight. Added weight must be of approved material, any exotic materials will not be allowed including but not limited to Tungsten or other high dollar materials. Any illegal material will become the property of the New London-Waterford Speedbowl and will not be returned.

1.4 GM Unaltered "602" Crate Engine

1. The preferred engine in the NLWS Truck Division is the General Motors "602" Crate Engine as supplied from GM with NO modifications. Unaltered GM part number: 88958602 & 19258602 only. The New London-Waterford Speedbowl is aware that other engine combinations have been, and are currently in use in various truck divisions across the country that utilize the same basic chassis as the NLWS Trucks. With that being said any legacy **(open)** engines such as the Chevrolet 305, Ford 302, and Dodge 318 will be allowed to compete following the rules originally written for those engines. Also there are a few crate engines based on the **Stafford Motor Speedway** SK Lite Engine package, those will be allowed as well with a few adjustments including weight until the **2022 Season**.

2. **Beginning in 2023 the only approved sealed crate motor is G.M. part number is 88958602 & 19258602, as supplied from GM.** This will be the ~~preferred~~ engine for competition in this division. Engine must remain sealed at all times with the factory GM Seals and **NLWS and/or Thompson Speedway Seals**. Any engine altered or modified in anyway without prior written approval, from the New London-Waterford Speedbowl, will result in permanent

suspension of that driver from all events for no less than one calendar year. This includes but not limited to Seal Bolts, Valve Springs, Rocker Arms, Shimming altering or relocating any part from its original configuration. The only approved alteration is the water pump and distributor. All other parts must remain as the motor came from General Motors. The GM Crate engine is factory sealed—any evidence of tampering with seals witnessed by the

NLWS race officials may result in an automatic full suspension of driver from racing at the New London Waterford Speedbowl for a period of one year. Request for reinstatement will be required. Further penalty for crate engine tampering will be a fine of all purse monies earned for the season + all points will be deducted from said truck and driver. If a crate engine is suspected to have been tampered with the New London-Waterford Speedbowl Officials have the authority to demand the removal of the suspect crate engine and have it tested. If the crate engine is deemed tampered with it will not be returned to its owner. It will become the property of the New London-Waterford Speedbowl. In the event of a crate engine failure, the engine will be removed from being allowed to compete in competition at the New London-Waterford Speedbowl, this means no rebuilding of motors. In the event of a minor failure requiring minimal repairs New London-Waterford Speedbowl Officials reserve the right to allow for a repair of said motor. Approval must be made in writing on a New London-Waterford Speedbowl letterhead before the authorized New London-Waterford Speedbowl rebuilder will be allowed to repair the motor. No other un-authorized builder will be allowed to repair any motor competing at the New London-Waterford Speedbowl. A Dyno sheet must be provided by the authorized New London Waterford Speedbowl rebuilder and given to the New London-Waterford Speedbowl Officials before motor will be allowed back into competition.

3. Valve Springs may be replaced as needed to maintain the power in the motor however the replacement springs must be GM Part # 10212811. If any other valve spring is found in a crate motor the motor will be deemed illegal and all points earned for the season will be forfeited.

4. Engine location is measured from the forward most spark plug centerline, to the imaginary line projected between the left and right, front, jack bolts. The forward most sparkplug centerline must be no less than 5.00 inches forward of this imaginary line.

5. All Crate Engines will be inspected using the GM Circle Track Tech Manual.

6. All Crate Engines will be registered via the seal serial number with the New London-Waterford Speedbowl.

7a. Beginning in the 2019 forward, any team switching to a crate engine must purchase a brand new, unused, (part #88958602 or #19258602) OEM GM Performance Factory Sealed Engine. It must be purchased from an authorized GM dealer. Invoice from the purchase must be presented with engine during registration when NLWS seals are installed. Any team that has a sealed, pre-registered, part #88958602 engine from 2017 may continue to use it, following existing rules. The GM crate engine manual will be used to inspect all crate engines, new or rebuilt.

Also, ALL crate engine ignition systems must be equipped with a working MSD rev limiter Part # 8727CT. Mounted to the engine side firewall, with all wiring visible. Maximum engine RPM must be set to **6500 RPM's**.

7b. Seals may only be removed by a NLWS Official or NLWS authorized service center. Any seals that appear to have been tampered with, or have been removed, without one of these two parties being present will result in the engine being deemed illegal. At this point, the engine must be re-sealed at the participant's expense.

NOTE: All engines must be sealed and documented to compete at New London-Waterford Speedbowl. A completed crate engine registration form must be completed and submitted to NLWS Officials. Engine seals are only good for two (2) years.

7c. This rule has been updated to include authorized service centers. If you have any questions regarding this rule please direct them to your division inspector.

The current NLWS authorized crate motor service centers are below:

Nat's Racing Engines
702 Warren Avenue
Swansea, MA 02777
(508) 336-4142
Contact: Nat Chiavettone

RAD Auto Machine
80 Ravenwood Drive
Ludlow, MA 01056
(413) 583-4414
Contact: Don Wood

1.5 Open Motors and other Crate Engines

1. Use of the 305 Chevy, 318 Dodge, or 302 Ford Motor is allowed following the rules in section 1.6.1. These motors must meet strict guidelines.
2. Use of the Stafford Motor Speedway SK Lite 602 Crate Engine is allowed. Any Stafford Motor Speedway SK Lite Type motor will be inspected to the current year Stafford Motor Speedway SK Lite Rule Book. This motor cannot be used in the NLWS Truck division after the conclusion of the **2021 2022 Season. (UPDATED 2-22-22)**
3. Weight penalties may be adjusted at the discretion of New London-Waterford Speedbowl Officials to equal out any advantages or disadvantages.
4. For the 2019 season only. The 350 Chevrolet Sportsman **Street Stock** engine may be used. See Specifications in the 350 Sportsman/Truck engine sections. **This engine may not be used after the conclusion of the 2021 2022 Season. (UPDATED 2-22-22)**

1.5.1 Open Motors Chevrolet 305, Ford 302, and Dodge 318

1. MAXIMUM COMPRESSION RATIO IS **9.5:1**. NO EXCEPTIONS.
2. The only engines legal for use in the NLWS TRUCK division competition are the Chevy 305, Ford 302, and Dodge 318, with stock factory bore and stroke for that type of engine, only. No custom strokes are allowed.
3. A maximum .060 inch overbore.
4. No titanium parts will be allowed anywhere in or on the engine.
5. No coatings of any type are allowed inside or on the engine.
6. No roller bearings will be allowed anywhere inside the engine except where specified in this Rule Book.
7. Engine location is measured on the right side (passenger side) from the forward most spark plug centerline rearward (and perpendicular) to an imaginary line connecting the left and right front weight jack bolts. The forward most spark plug centerline **MUST** be no less than 5.00 inches forward of this imaginary line for the Chevy, 7.00 inches for the Ford, and 1.75 inches for the Dodge.
8. Engine must be centered between frame rails.

9. Minimum crankshaft height is 12" from center line of crankshaft pulley bolt to the ground.

Blocks

1. Blocks must be factory, stock, and cast iron only. Chevy 305 cubic inch, Dodge 318 cubic inch, or Ford 302 cubic inch blocks only.
2. Blocks may be lightly de-burred only. No over machining of the block is allowed. Align honing, deck milling to square block only, and cylinder boring is acceptable if kept within the allowable specs, .060 inch overbore, maximum.
3. Torque plates may be used during machining.

Crankshaft

1. Only OEM Chevy, Dodge, and Ford supplied cast iron or steel crankshafts are legal.
2. No O.D. turning, lightening, knife edging, weight polishing or cross-drilling for weight removal will be allowed, except for "Mallory Metal", or minimal metal removal for balancing.
3. Any type harmonic dampener or flywheel may be used, SFI approved units are highly encouraged.

Connecting Rods

1. Only stock-type, OEM, cast or forged, iron or steel connecting rods allowed. No other rod substitutions will be allowed unless stated.
2. Center of rod journal to center of crank journal length must be stock for the particular type of engine.
3. No lightening, beam polishing, or exterior machine work allowed on rods, except bob weight removal for balancing.
4. Heavy-duty rod bolts, and heavy-duty stock, OEM connecting rods may be used.
5. Chevy may use the heavier duty rod from the 350 cubic inch engine in the 305. Fords may use the SVO available 5.0L HD replacement rod in the 302. Chrysler may use the P4349617 HD connecting rod in the 318.
6. Maximum rod length (center to center) Chevrolet 5.700, Ford 5.096, Chrysler 6.125.
7. The only machine work allowed on the rods is the removal of material for balancing and the setting of the side clearances.

Pistons

1. The only pistons permitted are cast or hypereutectic, dished or flat top, with the stock type (for that particular engine) ring package and compression height.
2. Pistons must be a stock type replacement piston. No custom made or lightweight pistons permitted.
3. No gas porting of pistons allowed.

4. Minimum deck heights are: Chevy 305 - 0.0 inches, Ford - 0.0 inches, and Dodge + 0.015 inches.
5. No excessive machine work on the pistons permitted. The only machine work allowed is for removal of minute material for engine balancing. One Piston in the engine must be as produced from the factory and unaltered.
6. No slant tops, angle milling, or excessive lightening of the pistons allowed.
7. Wrist pins must be the pressed in type; no lightweight or floating wrist pins; no wrist pin buttons.
8. Dodges may fly-cut the piston tops, .050 of an inch, maximum, on the exhaust valve side only.

Heads

1. Only factory production, cast iron heads that are OEM for the engine type being used that produce the factory specified volumes, are permitted.
2. No bowtie, angle-plug, special high-performance, canted-valve, or marine-type heads permitted
3. Chevy Vortec heads are permitted. Chevrolet Vortec head casting #'s 12557113, 12552520, 12558059 are permitted.
4. The Ford GT-40 (cast iron) and the GT-40P head are legal for competition.
5. The Chrysler or Mopar magnum-type heads are permitted.
6. Maximum valve sizes: Chevy 1.84 Intake, 1.5 exhaust Ford 1.84 Intake, 1.5 exhaust GT-40P 1.847 Intake 1.546 exhaust Dodge 1.84 Intake, 1.5 exhaust
7. Minimum combustion chamber volumes: Chevy 53cc, Ford 53cc, and Dodge 62cc.
8. No porting, port matching, excessive decking beyond the chamber minimum volume, angle milling, chamber polishing, or grinding allowed. Valve bowl area is to be untouched except as in guide replacement, and no machining or handwork allowed except a very minimal amount for seat installation. It must be as cast by the foundry. Except for valve seat grinding, seat replacement, deck and flange milling, valve guide replacement, crack repair, stem seal machining, and rocker stud boss machining and drilling, no other machine work is allowed.
9. Only the stock type steel or stainless steel valves are legal.
10. No four-angle valve jobs allowed.
11. Cutting for larger diameter spring is allowed. Any type guide material may be used. The valve guides must be in the stock factory location, angle, and spacing.
12. Valve springs must be of the stock type. No triple, conical, or progressive springs allowed. Any valve stem with a polish or undercut of .015" or more will not be allowed.
13. Valve spring pressure cannot exceed 120 pounds of seat pressure as measured on a New London-Waterford Speedbowl approved spring tester. Measurements may be taken cold or at race conditions and race temperatures.
14. Valve stems must be stock height only.
15. Retainers must be steel or chrome-moly steel only. Valve spring retainers must be stock type only. Plus or minus height retainers are allowed.

16. Valve spring keepers must be stock type only. No plus or minus height keepers allowed. Seven or ten degree locks may be used.

17. All heads must have visible and unaltered casting numbers and production date codes. Any heads with unreadable or altered casting numbers will be impounded immediately, and the competitor will be disqualified from the event.

Valve Train

1. Hydraulic lift cams only with a maximum lobe lift of .333. Camshaft lift may be measured at the valve, rocker arm, or directly on the camshaft. It may not exceed the gross valve lift, divided by the listed rocker arm ratio. Tolerance for camshafts will be +0.005.

2. Only hydraulic lifters allowed and must be able to pass a bleed down test. Anti-pump-up are lifters allowed.

3. No lightweight push rods allowed. Push rods may be sized to length to fit geometry. No rev-kits, stud girdles, offset rocker arms, full roller rocker arms, roller pivot rocker arms, roller lifters, light weight lifters, coated lifters, mushroom lifters, or oversize lifters are permitted.

4. Stock or roller timing chains are allowed. Torrington Thrust Bearings, to prevent block wear, are legal. No gear or belt drives allowed. Cam thrust-buttons are allowed. Camshaft degreeing is optional. After market rocker arm retaining nuts are allowed.

5. The Chevy rocker studs may be pinned or machined for screw in studs up to 7/16" and guide plates. Stock rocker ratios must be **1.5:1**. Stock (OEM) type roller tipped rockers are legal for NLWS TRUCK competition

6. The Ford rocker studs may be pinned or machined for screw in studs up to 7/16" and may use Ford factory, stock style, early 1.6: 1, non-rail rocker arms and guide plates. Stock (OEM) type roller tipped rockers are legal. Rocker arm pivot shims may also be used.

7. The Dodge may be converted to use the factory type Dodge truck adjustable rocker arms and push rods. The adjustable rockers must retain the stock ratio of 1.5:1. Stock (OEM) type roller tipped rockers are permitted.

8. Oil return screens are legal. Lifter valley baffles are legal.

Intake Manifold

1. The only intake manifold legal for competition is the Edelbrock Performer RPM series. Part numbers: Chevy #7101, 7116, Ford # 7121, Dodge #7176 may be modified to be used with Magnum Heads. The Edelbrock RPM Air Gap series, Chevy #7501, #7516, Ford #7521 intake manifolds must be "as cast" by Edelbrock.

2. Intake manifolds must be "as cast" by Edelbrock. No alterations to the manifolds will be allowed.

Milling to facilitate engine fit is acceptable. Intakes may be swapped with a new out of the box intake from the Waterford Speedbowl.

3. No drilling, porting, or port matching will be allowed. No acid dipping or other processes are allowed. All air drawn into the engine must be drawn in through and metered by the carburetor. No add-on devices are permitted inside the plenum or runners, and no coatings will be allowed inside or outside the intake manifold.

Air Cleaners-Applies to ALL Motors

1. Steel or aluminum air cleaner housings may be used. Air cleaner must be 12" minimum diameter, 16" maximum diameter, and five" maximum height. The air cleaner element must be unaltered and in place whenever the engine is running
2. The air cleaner must be totally covered by the hood. No holes, vents tubes, ducts, or any other devices may be used to guide air to the air cleaner unit with the exception of a Cold Air Box that meets NLWS Officials Approval. Absolutely no flow control items are allowed inside or outside the air cleaner, for any reason. No pulling of air through top or of air cleaner housing. The air filter must be open and unrestricted for 360 degrees. No shields, baffles, or other add-on equipment allowed.
3. No K&N air cleaner housings are legal for *New London Waterford Speedbowl* competition. K&N filter elements are legal for *New London Waterford Speedbowl* competition.
4. Cold Air Boxes are allowed, a slot in the back of the hood at the windshield is permitted. The slot must be no more than 60 Square Inches total.

Engine and General Engine Carburetor-Applies to ALL Motors

1. Holley two-barrel model #4412 carburetor may be used with only the below modifications. The body, base plate, metering block, and bowl must be a standard Holley 4412 part. HP parts are not permitted. Carburetors and/or carburetor components machined from billet materials are not permitted.
2. OEM type gaskets, jets and power valve must be used.
3. The diameter of every hole in the carburetor must pass the standard NASCAR/NLWS pin and tooling gauges as part of our routine inspection process.
4. The only changes that will be allowed are as follows:
 - a. The choke plate and shaft may be removed, but must be permanently sealed.
 - b. Throttle plate screws may be trimmed flush with the shaft.
5. Body of carburetor and metering block: No polishing, grinding or reshaping of any part. Drilling of additional holes or plugging holes is not permitted.
6. Choke horn may not be removed.
7. Boosters may not be changed. Size or shape must not be altered. Height must remain standard.
8. Venturi area must not be altered in any manner. Casting ring must not be removed.
9. Alterations to allow additional air to be picked up below the opening of the venturi such as altered gaskets, base plates, and drilling holes into the carburetor will not be permitted.
10. Base plate must not be altered in shape or size.
11. The stock Holley 4412 or Stainless Steel Holly part #346 butterflies must be used. They may not be thinned or tapered. The Butterflies must remain as manufactured, and must maintain the Holley production tolerance
 - a. thickness of .0438" to .0398". Idle holes may be drilled in butterflies. Screw ends may be cut even with the shaft but screw heads must remain standard.
 - b. Throttle shaft must remain standard and must not be thinned or cut in any manner.
12. Holley 4 bbl. Carburetor may also be used with only the below modifications.
 - a. The Holley 650 cfm four-barrel P/N 80541-1 carburetor must be used. Polishing, grinding, resizing or reshaping of any part or orifice is not permitted.
 - b. The body, base plate, metering blocks, and bowls must be a standard Holley 80541-1. HP parts are

- not permitted. OEM type gaskets, jets and power valves must be used.
- c. The diameter of every hole in carburetor must pass the standard NASCAR /NLWS pin and tooling gauges as part of our routine tech process.
 - d. Body of Carburetor and metering blocks: No polishing, grinding or reshaping of any part. Drilling of additional holes or plugging holes is not permitted.
 - e. The choke may be removed, but all screw holes must be permanently sealed. Choke Horn: Choke horn may not be removed.
 - f. Boosters: Boosters may not be changed. Size or shape must not be altered. Height must remain standard.
 - g. Venturi: Venturi area must not be altered in any manner. Casting ring must not be removed.
 - h. Alterations to allow additional air to be picked up below the opening of the venturi such as altered gaskets, base plates and drilling holes into the carburetor will not be permitted.
 - i. Base Plate: Base plate must not be altered in shape or size.
 - j. Butterflies: The stock Holley 80541-1 butterflies must be used. They may not be thinned or tapered. The Idle holes may be drilled in butterflies. Screw ends may be cut even with shaft but screw heads must remain standard.
 - k. Shaft: Shaft must remain standard and must not be thinned or cut in any manner.

.All carburetors are subject to testing with New London-Waterford Speedbowl Carburetor Tools. Any carburetor failing the go no go tools, other inspections, or failing to conform to the intent of the rule will become the property of the New London Waterford Speedbowl.

13. Ignition System-Applies to ALL Open Motors

1. OEM or OEM-replacement HEI distributor permitted. HEI, aftermarket type distributor modules or coils may be used but must mount in OEM distributor location.
2. MSD ignition #6AL6420 and #64306ALN, or MSD Soft Touch Rev Limiter systems are REQUIRED. The external mounted coil may be used.
3. Wire Ends must be original factory MSD or weather pack connectors installed by MSD.
4. MSD must be located on the right side of dash panel, as far from driver as possible, and out of reach.
5. All wires must be wrapped in a loom material, and must pass through firewall at first option. Rivets to hold bottom panel must be drilled out.
6. Only one MSD box allowed. Any altering of MSD box will result in disqualification and possible suspension.
7. Ignition Boxes may be swapped at the discretion of New London-Waterford Speedbowl Officials.
8. **For motors 325 Cu. Inches or less, a Maximum 6800 rpm Rev Limiter Chip or digital setting is mandatory. For motors 326 Cu. Inches or more, A maximum 6500 rpm Rev Limiter Chip or digital setting mandatory.** Limiter Chips must be used or limiter set to the specified maximum whenever the MSD Box is installed. Chips and MSD Boxes will be tested and subject to random swap at any time. Track may change the specified rev limiter settings if needed during the season.

1.6 Electrical System

1. Any Alternator is permitted.
2. Only one standard 12-volt battery permitted. 12-volt Gel Batteries are permitted and recommended.
3. Battery must be mounted behind driver's seat, on the left frame rail against the rear firewall.
4. All electrical switches must be located on the dash panel or within easy reach of the driver.
5. A master battery shut off switch must be installed within reach of the driver and clearly marked "on" & "off".

1.7 Engine Cooling System

1. Water Pump must be STOCK OEM style for your engine. Aluminum water pumps are allowed. No Electric Water Pumps allowed.
2. Any automotive style radiator is allowed. Aftermarket Aluminum Racing Radiators are allowed. The radiator must be in the stock location. Water and "water wetter" brand additive are the only coolants allowed. A minimum 1-quart over flow can, must be mounted under the hood on the right side. A venting hose pointing up from the catch can must be located at the base of the windshield must be installed.

1.8 Engine Exhaust System

1. Only stock type, or "up and over" headers are legal for New London Waterford Speedbowl competition. No headers with 180-degree design (cross over): stainless steel, ceramic coatings, or merge collectors are allowed. No spread port adaptor flanges are allowed. The maximum exhaust ID is 3 inches. The maximum cost of the headers cannot exceed three hundred dollars (\$300.00).
2. Exhaust equalizer "H", "X", and "Y" pipes are legal. All exhaust systems must exit past the driver's compartment. The minimum exhaust system ground clearance is 3 inches. Schoenfeld headers are recommended. Approved header heat shields are legal.
3. Exhaust mufflers are required. Approved mufflers for competition are the Lobak #RCM-25-12-25 or Lobak #RCM-30-12-30, Moroso Spiral Flow #94051 or #94050, Schoenfeld Headers 83030, with both ends as supplied from the manufacturer unmodified. MUFFLERS MUST BE REMOVABLE FOR INSPECTION. Only one muffler per header permitted. Any installation is subject to approval of *New London Waterford Speedbowl* officials. Exhaust will not be permitted to exit out the side of the truck. All exhaust must be pointed towards the ground at a 90 degree angle.

1.9 Drivetrain

1.9.1 Automatic Transmission

1. The only Automatic Transmissions legal for New London-Waterford Speedbowl competition are the Chevy Turbo-350, Ford C-4, C-6, and Dodge Torqueflite Transmissions.
2. Automatic Transmissions may be converted to manual operation. Steel and cast hubs are allowed. Transmissions must use a fluid filled torque converter with a minimum diameter of eleven inches, with 0.20 inches allowed for manufacturer's variance. The maximum legal stall speed is 3,000 RPM. Modifications may be made to internal transmission parts for durability only. The transmission must have all forward and reverse gears functional. Transmission oil cooler size and placement is optional.
3. Lockout shifters are allowed.
4. No solenoid lockups or fluid clutches.
5. No extra hand or foot controls allowed.
6. A one-quart catch can is required from the overflow.
7. Transmission cooler may have a fan and ducting leading to the fan. Fan and ducting must seal to the cooler and may not exceed more than 36" from the cooler.

1.9.2 Standard Transmission

Transmission

1. The only manual transmissions allowed are OEM 3 or 4 speeds. Cast iron or aluminum case.
2. There are no modifications allowed to the transmission.
3. The transmission mount may be stock or fabricated.
4. None of the following will be allowed in or on the transmission or transmission parts:

No REM Machining, REM type Processes, Abrasive cleaning, Acid dipping, Chemical milling, Epoxying Finishing, Internal Painting, Plating, Polishing, Porting, etc.

Flywheel and Clutch

1. A stock OEM steel flywheel or a replacement steel billet flywheel with OEM stock dimensions must be used.
2. Pressure plate must be stock OEM or a stock OEM replacement, with a minimum diameter of 10.4".
3. Clutch disc must be stock OEM type, with a minimum diameter of 10.4"
4. Minimum weights: Flywheel-(no bolts) 20lbs. Pressure plate-(no bolts) 13lbs. Clutch Disc-3lbs.
5. Drilling or lightening of any part is not permitted.
6. Steel bolts only. Flat surface machining allowed only on the face side of the flywheel, any cutting on the back

side of the flywheel is illegal. Stock OEM or aftermarket clutch pedal and master cylinder assembly are allowed. Stock type mechanical linkage or hydraulic slave or throw out bearing are allowed.

Bellhousing

1. A commercially manufactured blow-proof steel bellhousing made from a minimum of 1/4" magnetic steel must be used.
2. It must fully enclose the flywheel and clutch completely, 360 degrees around.
3. An opening no larger than 3-1/2" x 4" may be used for throw out bearing access.

1.10 Rear End

1. The ONLY approved rear ends are as follows, GM 10 Bolt 7.5", GM 12 Bolt 8.5", and Ford 9-inch Rear End. Any Rear End using a 4-Link rear suspension, must bolt in place of OEM GM 10 bolt utilizing all 4 rear links and factory mounting holes. The use of 3-Link Rear Suspension Setups is permitted. Any truck using a 3-Link Rear Suspension Setup must add 50lbs to your total weight.

Aftermarket Johnson or Hamm Chassis. No internal modifications of any type allowed. No cambered rear ends. No bending, twisting or rotating of axle tubes, perches, or mounts. The final drive gear ratio cannot exceed 6.25 at the rear end. Ford 9" inch rear ends must follow the below listed rules:

2. All steel no aluminum except for drive flanges and caps,
3. Steel mini spool or steel full spool (8lbs min) allowed, no lockers or ratchets of any kind allowed,
4. Ford 9" Rear Ends using a 4-Link rear suspension, must bolt in place of OEM GM 10 bolt utilizing all 4 rear links and factory mounting holes. The use of 3-Link Rear Suspension Setups is permitted; you must add 50lbs to your total weight.
5. Differentials may be open or locked. When locked, they must be welded securely or locked with a mini-spool, or full spool. No aluminum spools or ratchet (Detroit Locker) type units allowed. The Auburn Gear L/S differentials are legal for competition. The Auburn Gear differentials are for the GM 7.50", 10-Bolt rear ends. The part numbers are; AUB 542057 and AUB 542058 for the 26-spline; AUB 542041, and AUB 542040 for the 28-spline. Also legal is the Lock-Right differential by PowerTrax and the OEM posi-trac units (for 7.5" & 8.5" Chevy) with no modifications.
6. Axle-saver bearings, c-clip eliminators, heavy-duty c-clips, and heavy duty aftermarket axles are allowed and recommended.
7. No gun-drilled axles allowed. Axles must be steel
8. The upper torque arms at the rear axle housing may be shortened to correct the pinion angle. Adjustable upper and lower rear control arms are legal. These may be made as simple as 2 Heim Joints with a Radius Rod between them or may be a Stock Replacement Kit for each of the 4 links. All Control Arms must mount in the Stock Mounting Holes on the chassis and on the rear end.
9. No devices are allowed that limit or restrict rear suspension travel. These include but are not limited to Bump Stops, Coil Spring Binding, Chains, etc. Chains are allowed between the rear end housing and the upper spring bucket to assist in holding the springs in while working on the truck. REAR SUSPENSION DEVICES MUST ALLOW THE

FRAME RAIL TO BE RAISED A MINIMUM OF 4" BEFORE THE REAR TIRES COME OFF THE GROUND.

10. All drive shafts must be painted white and have the truck number on it. Stock type steel drive shafts only. No lightweight, aluminum, chrome-molly or carbon fiber, drive shafts will be allowed. No drive shafts smaller than 2.00 inches in diameter allowed. Two drive shaft loops must be installed. One loop between the transmission and the aft side of the driver's compartment; and one loop between the aft side of the driver's compartment and the rear universal joint. The loops must be made of a minimum 2" x 3/16" flat bar steel, or 1" round, .095" steel tube. Loops must go completely around the drive shaft. Chain, wire or other installations will not be allowed.

1.11 Suspension

1. Spindles, and brake calipers must be stock OEM, in the stock location, Spindles and front brakes may be changed to heavy duty OEM units (GM Impala). They must be bolt on units and not be altered in any way except the lower ball joint hole may be reamed or tapered to fit the lower ball joint pin. No aluminum spindles. Brake Calipers must be in the stock position. No modifications allowed. Spindle must be reamed with same taper as ball joint. Spindle Savers are permitted and recommended.

2. Lower Control Arms may be the stock OEM "G" Metric Lower Control Arm, or a stock aftermarket "G" Metric replacement. Lower Control Arms must mount in the Stock position. Johnson Chassis Lower Ball Joint part #JCI-09-02-01RCSP and the Chrysler K-727 style lower ball joints are allowed

3. Steel Upper "A" arms can be any length, non-adjustable only. No modifications of A-arms allowed. Aluminum cross shafts are allowed.

4. Aftermarket Replacement, heavy-duty front hub assemblies are permitted. Colman or similar are permitted.

5. No devices are allowed that tie down, limit or restrict front suspension travel. These include but are not limited to Bump Stops, Coil Spring Binding, Chains, etc.

6. Any manufactured Racing Spring is allowed. The rate may be changed. No custom wound springs allowed. No Coil Overs Allowed.

7. Any steel bodied, shock allowed as long as it is non-adjustable while on the vehicle. Shocks must be available commercially and have a maximum price no greater than **\$170.00** advertised racers net price. No custom built shocks allowed. No shocks with Schrader Valves for adjustment OR Nitrogen Charging allowed. Only one shock per wheel is allowed. Shocks must remain as manufactured. Rear shocks must be at a 70-degree angle +/- 5degrees, measured with an inclinometer on the main body of the shock. Tolerance of +/- 2 degrees. Steel bodied, rebuildable shocks are legal for competition.

8. Any General Motors or stock type sway bar that mounts in the stock location, without alteration, with a maximum diameter of 2 inches may be used. No adjustable or controllable sway bars allowed.

9. Stock rubber or approved polyurethane bushings are allowed on the chassis and suspension. Steel front and rear bushings are legal for competition. No eccentric/offset bushings or non-factory adjustable devices allowed on the suspension. Bushings on the upper mounts of the rear end housing only may be of the swivel bearing type.

10. The stock type steering box must be used, and bolt on in the stock location, using the factory Frame holes. Inner tie rods, idler arm, pitman arm, center drag link must be stock type, OEM, for the GM, "G" body, 108.1", metric frame being used. Outer tie rod end and adjustment sleeve may be replaced with a 5/8" steel rod end and steel tube or aluminum. Heim joints in the inner and outer steering tie rods are permitted. The three steering box

bolts may be drilled and safety wired. Adjustable idler arm and bump steer correction drag link may be used.

11. Maximum tread width is 73" measured from **outside of the Left Rim** to **outside of the Right Rim**.

1.12 Brake System

1.12.1 Brakes

- a) Brake systems must be stock OEM hydraulic systems. All four (4) brakes must be in working order. Disc brakes are allowed in the front only. Ultra Cool PART # LMBFS5-625 L or R hub mounted cooling fans may be used on front brakes. One per wheel.
- b) No drilling or lightening of any brake parts. No rotor may be machined thinner than the minimum thickness stamped on the rotor. All necessary machining for regular rotor maintenance must be removal of equal amounts of material from both surfaces of the rotor. This removal must remain within the minimum thickness stamped on the rotor. No cross drilling, gas slotting, or any other machining to enhance rotor cooling or performance.
- c) Aftermarket master cylinders/pedals are allowed.
- d) Adjustable proportioning valves are allowed – front to rear adjustment only.
- e) Air ducts, no larger than 4" in diameter, may be used to cool the brakes.

GM aftermarket caliper produced by Howe (part #HOW337 or HOW33658) may be used. That part must have the Howe logo.

g) Rear disc brakes may be installed. Stock G-Body metric calipers only. Calipers must be mounted in same position left to right side. Steel caliper slider pins only. Steel caliper brackets only. May be welded or bolted to housing tubes or tube flanges. Speedway Motors rotor part #91031043 is the only approved rotor at this time. Maximum rotor diameter 11.630" inches. No drilled, scalloped or slotted rotors. No lightening of brake rotors in any way.

1.13 Fuel

1. DEFINITION: The word "Fuel", whenever used in this document shall be understood to mean automotive gasoline which complies with the specifications given in this section.

2. FUEL SPEC'S: Sunoco Race Fuel 260GTX and 93 octane Super Unleaded automotive pump gasoline are the only fuels permitted in the Truck Division. The 93 octane Super Unleaded automotive pump gasoline must be purchased from a retail outlet and must contain a minimum of 7 percent and a maximum of 10 percent of ethanol. The use of an additives or catalysts is not permitted. These two fuels may be mixed together. Several testing procedures will be utilized to insure that all racers use only approved fuels. Icing or cooling of the fuel system is not permitted at any time. Fuel may be tested and certified at any event through the application of

various chemical analyses as considered appropriate by New London Waterford Speedbowl Officials.

3. FUEL SYSTEM: Fuel cells, containers, or check valves which appear to be damaged will not be allowed in competition. Fuel cell vent check valves are mandatory.
4. FUEL CELL: The use of a commercially manufactured fuel cell is mandatory. The maximum fuel cell capacity, including the filler spout and overflow, is 22 gallons. No material other than standard foam as provided by the fuel cell manufacturer is permitted to make the fuel cell meet the 24-gallon capacity.
5. FUEL CELL CONTAINER: The use of a magnetic steel fuel cell container is mandatory. The fuel cell must be encased in a steel container of not less than 22 gauge (.031") steel. Fuel cells must be fitted within the container so that the maximum capacity, including filler spout will not exceed 22 gallons.
6. The fuel cell and fuel cell container must be installed as far forward as possible, centered between the frame rails and behind the rear axle. A "cage" for the cell must be constructed out of 1" minimum steel tubing. This "cage" must be attached to the cars frame rails using 1" (minimum) steel tubing. The fuel cell container must be secured on top by 1" x 1" square steel tubing or 1" x 1/8" thick steel straps, two lengthwise and two crosswise. The straps must be located as close to the fuel filler/check valve housing as possible. No part of the fuel cell container may be lower than 8" in race-ready condition with the driver sitting in the seat.
7. FUEL FILLER: The gas cap must be painted white with your car number on it for identification.
8. FUEL CELL VENT: A 1" maximum ID vent to outside of body at left rear corner must be used. A fuel vent check valve is mandatory.
9. FUEL LINES: Only one fuel line is permitted from fuel cell to fuel pump, and one fuel line permitted from fuel pump to carb. The fuel line can be no larger than 1/2" ID. The fuel line from cell to pump must remain under floor of the truck.
10. FUEL SHUT-OFF: A 1/4 turn fuel shut-off valve is required in the fuel line. The fuel shut-off valve's ON and OFF positions must be clearly labeled. The valve must be open when the handle is aiming front to back, and the valve must be closed when the handle is aiming left to right. No fuel shut offs on driver's side. Must be accessible to the track safety crew.

1.14 Tires and Wheels

1. A track tire rule is in effect. For the New London Waterford Speedbowl Trucks it is the Hoosier "970" Tire.
2. All tires must be purchased from the track tire dealer. Dealer of record is Hoosier Tire East.
3. No shaving, grooving or altering the physical appearance of the tire is allowed.
4. The use of tire altering chemicals is forbidden ("soaking", inside or out).

Notice: Participants competing in any race at the New London Waterford Speedbowl specifically agrees that he/she acknowledges that it is illegal to soak or treat racing tires and that said soaking or treatment of racing tires is against EPA regulations and further contains carcinogens and hazardous materials which is unfit for his/her health, and the health of all competitors and spectators.

5. All wheels being used must be magnetic steel, heavy duty 15" diameter x 8" wide only. A 2" or 3" offset is allowed. Wheels must weigh a minimum 19lbs.
6. ONE (1) single ½" spacer is allowed per wheel. No Stacking of spacers allowed.

1.15 Accessories

1.15.1 Electronics

1. No onboard computers, automated electronics, recording devices or digital readout gauges of any kind are permitted.
2. All teams must get approval before using any in-car camera equipment.
3. All Video Recording Devices must be registered with the New London Waterford Speedbowl.
4. A Video Camera Registration Form must be filled out and on file with the New London Waterford Speedbowl prior to using any recording devices.

1.16 Roll Cage

1. An "ear" bar, located vertically by the driver's head is mandatory. It should be placed as far forward as possible, while still allowing the driver easy entry and exit from the truck. Commercially manufactured roll bar padding must be used on all bars within driver's reach. No truck with less than the minimum roll cage standards will be allowed to compete. All mandatory roll cage tubing must be placed as described.
2. A magnetic steel anti-intrusion plate (door bar plate) made from a minimum thickness of .080 must be securely welded to the outside of the left side door bars. The anti-intrusion plate(s) must fill the area between the horizontal centerlines of the top and bottom door bars, and vertical centerlines of main roll bar, and the left front roll bar leg. The plate(s) must be formed to match the curvature of the door bars. Individual plates, if used, should be made as large as possible. All plate(s) must have the corners welded. To facilitate emergency removal of the left side door bars, the anti-intrusion plate(s) must have 4 (four) 2-1/4" diameter holes cut in the anti-intrusion plate, to allow the "jaws of life" to get access to the roll cage door bars.
3. All trucks must have a foot protection bar, made from 1-3/4" diameter roll cage tubing installed on the left side of the roll cage. The foot protection bar must be located at the pedal assembly, when viewed from the side and above. The foot protection bar must be installed between the left front roll cage "down bar" and the left frame rail. This bar must be padded.

New London-Waterford Speedbowl officials reserve the right to interpret any and all of the above the written rules in any way, under the guidelines of the published NLWS Truck division rules.

Appendix A:

Original American Race Truck Chassis

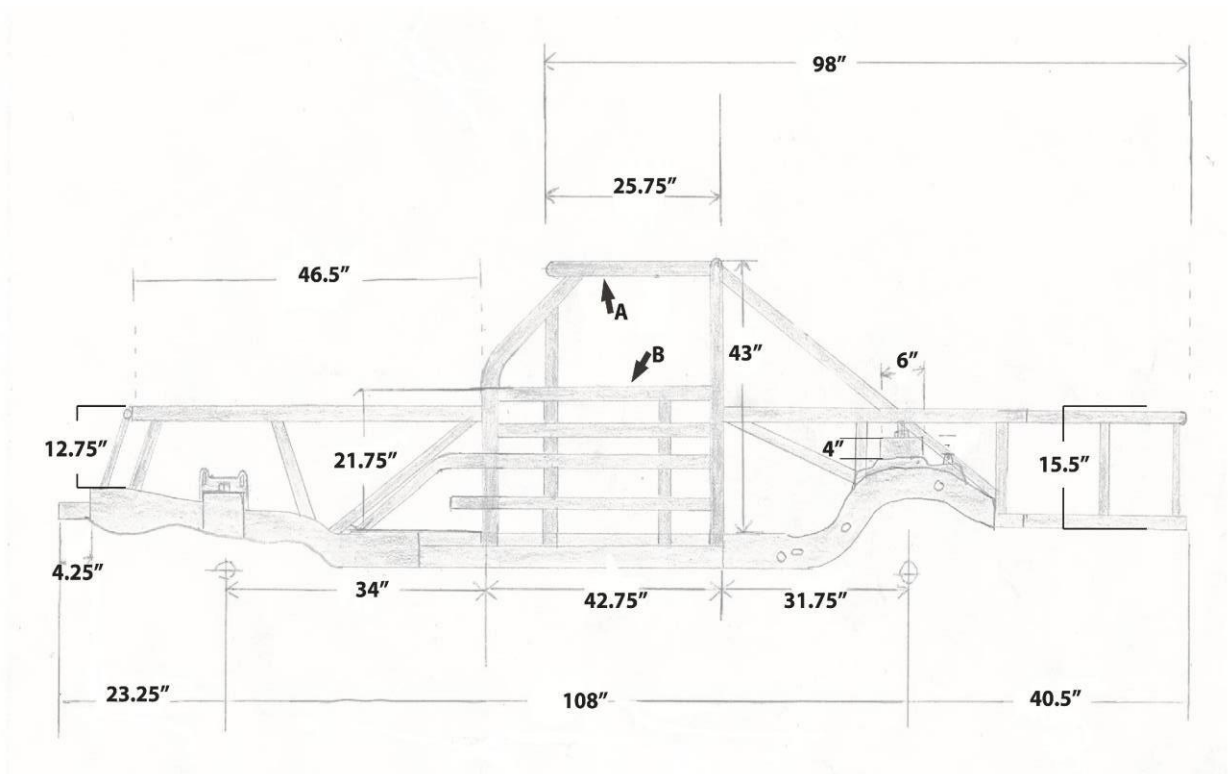

Appendix B: New Updated Chassis

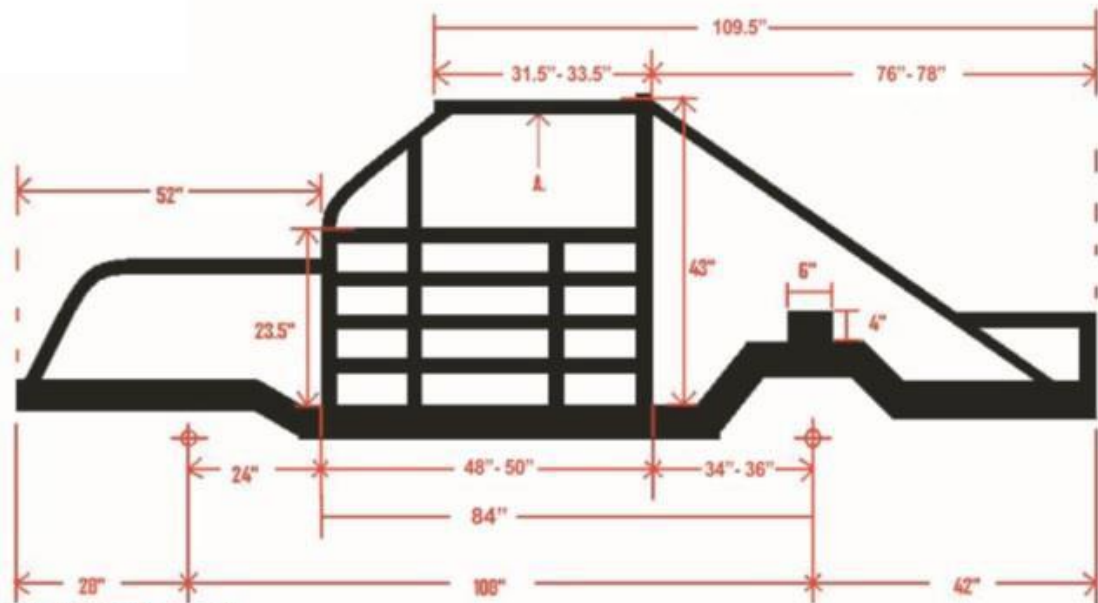

- A. Minimum hole width 48" (outside to outside)
- B. All tubing shown in these dimensions must be 1.75" O.D in diameter (minimum .090 wall thickness)
- C. Design and construction of chassis must be as shown in illustration 3 (NO EXCEPTIONS)