

## 2024 New London-Waterford Speedbowl SK Modified® Rules

### 1) Introduction:

Interpretations of the rules contained herein will be the sole responsibility of authorized officials of New London-Waterford Speedbowl. Their interpretations and judgments shall be final.

All equipment is subject to the approval of the New London-Waterford Speedbowl Officials.

It is the competitor's responsibility to become familiar with the SK Modified® Division Rules and the New London-Waterford Speedbowl General Rules.

#### Contact Information:

Joseph Delorimiere - New London-Waterford Speedbowl Technical Director

Email: grip340@aol.com

Phone: 860-514-1713

Mark St. Hilaire - New London-Waterford Speedbowl Technical Inspector

Phone: 860-919-4141

### 2) Driver Eligibility:

Drivers 16 years old and up are eligible to compete in the New London-Waterford Speedbowl SK Modified® division. In order to participate in any on-track activity all cars must complete a technical & safety inspection and all drivers must be signed in with all completed paperwork on file. This includes Driver Registration Form and Number Registration Form. By registering as an owner or driver you agree to be knowledgeable and bound by the contents found in these rules and in the New London-Waterford Speedbowl General Rules.

### 3) Safety:

#### Racing Seat

An aftermarket, aluminum fabricated racing seat, sized correctly for the driver, must be used. See General Rules for detailed requirements.

#### Seat Belts

A minimum 5-point safety harness is mandatory. Belts must be SFI rated and dated no older than 3 years from the date of manufacture. See General Rules for detailed requirements.

#### Window Net

A commercially manufactured, SFI rated, nylon window net must be installed in the driver's side door window opening **and dated no older than 3 years from the date of manufacture**. See General Rules for detailed requirements.

## Fire Suppression

A fire extinguisher or fire bottle suppression system securely mounted in the car is mandatory. See General Rules for detailed requirements.

## Safety Gear

A double-layered, full fire suit made of Nomex material is mandatory. SFI rated gloves and shoes are mandatory. Full-face SA2005 rated or newer helmets are mandatory. A head and neck restraint system (Ex: HANS, Hutchens, or similar) is mandatory. See General Rules for detailed requirements. **The SCD, steering coupling device, manufactured by LaPlante Racing Products, [www.laplant racingproducts.com](http://www.laplant racingproducts.com) has been approved for competition in 2024.**

## 4) Transponders & Radios:

All cars must have functional transponders in order to participate in any on-track activity (see Figure 1 for mounting location).

Spotters are mandatory. Teams must monitor the race control frequency (464.5000) and comply with all requests from race control.

One (1) rear view mirror mounted at the top of the windshield is permitted. Maximum mirror size is 14" X 2". (1) 3" maximum spot mirror is permitted.

## 5) Technical Rules:

No carbon fiber or titanium parts allowed. None of the following will be allowed in or on any engine or driveline component or part: abrasive cleaning, acid dipping, chemical milling, coating, epoxying, finishing, grinding, painting, plating, polishing, porting, etc.

Electric cooling blowers are not permitted in any system of the car besides the radiator and oil cooler.

Outlook Notes:

~~Built Engine Option~~

~~2025: Not permitted~~

~~Shocks~~

~~Spec shocks to be investigated.~~

## 6) Approved Models:

Approved model bodies are listed in the NASCAR Rulebook. Detailed chassis, body, and interior tin rules can be found in the NWMT rule book.

**6.1 The Thompson Speedway 604 Modified will be permitted in the SK Modified ® Division. Any car running under the Thompson Speedway 604 Modified Rules must meet those rules 100%,**

**except for overall weight which is 2525lbs. There is no mixing of rules from any rules package.**

**For questions regarding any other modified division that runs the GM 604 Crate Engine contact Mark St. Hilaire - New London-Waterford Speedbowl Technical Inspector  
Phone: 860-919-4141**

## **7) Body, Appearance:**

Cars may not compete without the roof, windshield, hood, air filter or mufflers in place. Additionally, the bumpers and all nerf bars must be adequately secured to the chassis at all times. NLWS Officials will pass judgment on any damage to the body, bumpers, nerf bars, etc. prior to continuing an event.

### Roof

All roof panels must be made of magnetic sheet steel or be an approved manufactured fiberglass roof. All cars utilizing an approved fiberglass roof must install the (minimum) 1/8" thick aluminum anti-intrusion plate in the roll cage halo (see figure 2).

### Roof Posts

The front roof posts may be aluminum or clear lexan. They may not be any higher than the line created from the roof attaching point to the forward most door attaching point. The rear roof posts must be aluminum and may not be any higher than the line created from the roof attaching point to the rearward most attaching point on the quarter panel. The rear roof posts must be a minimum of 49" apart when measured across the car from left to right and may not be inboard of the rear spoiler mounting area. The general shape and any cutouts in the rear roof posts must match from left side to right side. A 3/4" maximum top lip is permitted on the rear roof posts, and must face inboard.

### Windows

Windshields must be made of minimum 1/8" clear polycarbonate that extends from the left A-pillar to the #4A center windshield bar and from the roof to the cowl. A minimum of three Dzus type fasteners must be used on each of the four sides.

### Doors and Quarter Panels

Door and quarter panels may be made of magnetic steel or aluminum.

Right side panels: The top and bottom door flange must match the top and bottom quarter panel flange, creating one line/plane when viewed from the side and above.

Left side panels: one angle or break is permitted at the door / quarter panel seam.

All doors and quarter panels must be flat or convex in shape, they may not be concave.

The bottom flange of the door and quarter panels must face inward / inboard.

The door panels must maintain a 2" minimum ground clearance.

The quarter panels must maintain a 7-1/2" minimum ground clearance.

Inner panel aluminum crush panels must be installed.

### Nose panel

A conventional aluminum nose panel must be used. The nose panel must consist of a bottom tray, two side panels, and a top panel. Additional panels to aid in air directional flow may be installed inside the nose panel. Any additional air directional flow panels may not extend outward from the air intake opening or any part of the nose panel. The nose panel may be no wider than the frame rails it attaches to. The bottom tray may not extend rearward past the harmonic balancer. The nose panel

may not extend forward beyond the rear edge of the front bumper tubing. The top and bottom panels must attach flush to the side panels. **The nose panel assembly must maintain 2" of ride height clearance.**

#### Nose Panel Air Intake Opening

The top panel must have an air intake opening with a minimum of 165 square inches and a maximum of 350 square inches. The air intake opening must be rectangular in shape. A metal mesh

screen may be installed in or behind the air intake opening for debris protection. A flat horizontal air dam (splitter) may be installed on the bottom forward lip of the nose panel. The air dam may be no wider than the nose panel, and may extend forward a maximum of 1" from the bottom tray.

**The air dam may not extend forward beyond the rear edge if the front bumper tubing.**

#### Rear Panel & Spoiler

The spoiler must be 8" tall x 48" wide x ¼" thick clear polycarbonate. The rear panel must be no wider than 60" when measured across from left to right. The height of the top of the rear panel must be between 32" and 36". The rear spoiler must be mounted to the top of the rear panel, aft edge, and must be centered across the back panel.

#### Interior Sheet Metal

The rear center panel (over the fuel cell) must be made of magnetic sheet steel, 22 gauge, .031" thick, with a minimum width of 28", and must extend from the rear vertical panel forward to the roll bar.

### **8) Weight:**

All specified weight requirements are driver included. Car minimum weight must be labeled on the right A-pillar of the car.

The minimum total weight is 2,645 lbs.

The maximum left side is 56.0% of the total weight.

Any car found to be under the minimum overall car weight allowance will be penalized one position for every pound under the minimum total weight.

All ballast weight must be magnetic steel or lead only, in block form, weighing no less than 5 lbs per block. Pellet weight is not permitted. Weight must be welded in a box or attached with (2) or more 7/16" minimum diameter, grade-8 bolts and locking nuts. Added weight may be mounted under the car, securely bolted or welded as high as possible, and painted white with the car number labeled in black. No added weight will be permitted inside the driver's compartment.

### **9) Frame & Chassis:**

#### Roll Cage

1-¾ diameter x .095 HREW or DOM steel tubing is mandatory for all roll cage bars. A magnetic steel anti-intrusion plate made from a minimum thickness of .080 must be securely welded to the outside of the left side door bars. All cars must have a foot protection bar located at or in front of the pedal assembly. All roll cage, foot protection bar, and anti-intrusion plate joints must be suitably and appropriately welded by competent craftsmen. See General Rules for roll cage, foot protection bar, and anti-intrusion plate detailed requirements.

### **10) Ground Clearance:**

Minimum ground clearance for chassis, body, and nose piece is 2". All ground clearance requirements will be measured with the driver in the car.

## 11) Track Width:

Maximum allowable track width is 83-3/4", measured at wheel center height from the left outside bead seat to the right outside bead seat. Minimum allowable track width is 82". Aluminum or steel wheel spacers are permitted.

## 12) Suspension:

Only coil spring suspensions are permitted. The suspension and coil springs at all four wheels must be active and permit suspension movement in compression and rebound. Any device or procedure that, in the judgment of NLWS Officials, attempts to detract from or compromise suspension travel movements will not be permitted. Any type of travel limiter devices, used in compression or rebound, will not be permitted. Any type of spring coil binding is not permitted.

A maximum of two full (360 degree) non-adjustable spring rubbers are permitted in each coil spring.

Shock/Coil over boots or bags are not permitted.

### Coil Over Springs

Only one (1) spring per wheel is permitted. Coil over springs must mount to the lower A-frames. Strut bars will not be permitted for mounting of coil over front springs. Coil over springs must be manufactured from one solid piece of heavy-duty magnetic round steel and must be constructed with both coil ends closed and ground. Progressive or digressive rate springs are not permitted. Coil springs must be a minimum of 8" in free height and have a minimum 250 lbs. per inch rating.

Additional devices to alter the load on the front springs are not permitted.

### Coil Over Shocks

**The following shocks are permitted for competition in 2024:**

JRI – 200-426 **with piston # XXX** and 200-427 **with piston #XXX**

Penske – 7500 series or 7150 series **with piston #XXX**

Pro – AC series

QA-1 – 62 **Series with piston #XXX**

**TFR-PL-DL005-1DG**

Shocks will be disassembled and/or dyno'd for inspection and comparison. The quantity and the thickness of factory supplied shims on the piston may be altered. The piston shim stack and the shock oil are the only components that may be changed, every other component must remain as factory produced by the shock manufacturer. All shocks must be either non-adjustable or single adjustable, available to all competitors, and a "race ready" published price of ~~\$440~~ **\$500.00** or less, less any separate coil-over kits. All shocks are subject to approval by NLWS Officials.

### Sway Bar

The front sway bar must be used for the purpose of anti-roll only. The front sway bar must freely rotate in its mounts. The movement of the front sway bar arms must not be prevented or restricted beyond normal use as an anti-roll bar. Only magnetic steel front sway bars are permitted. Rear sway bars are not permitted.

## Spindles, Hubs, and Bearings

Front spindles must be linked to the frame utilizing two individual tethers per spindle.

Low drag components (excluding seals) are not permitted. The use of oil filled hubs, oiled bearings, low friction bearings, non-steel bearings, coated or polished spindles, bearings or races will not be permitted. Two standard steel wheel bearings, a wheel bearing seal, a torque nut and a standard nut locking mechanism are the only components permitted on each spindle/hub assembly.

## 13) Brakes:

Four wheel disc brakes are mandatory. Only magnetic cast iron or cast steel round circular rotors permitted. Only metal brake calipers will be permitted. Drilled, slotted or grooved rotors are not permitted. Only factory dust cleanouts are permitted. Dust cleanouts should not exceed .038 in depth. If the dust cleanout exceeds .038 in depth, the rotor may be deemed illegal. The brake rotors must be bolted directly to the hubs. Floating brake rotors are not permitted. Only single stage master cylinders are permitted.

## 14) Tires:

Hoosier Tire East of Manchester, CT is the sole tire supplier for the SK Modified Division. The approved compounds are Hoosier 27/13-15 M450 right sides and Hoosier 26/13-15 M30 left sides. All tires used at NLWS must be purchased at the track on race day. NLWS Officials may confiscate and/or impound tires at any time for inspection.

Minimum circumference of the right rear tire is 84" at 20 lbs of pressure. Minimum Tire Pressures for all inspection purposes are ten (10) psi for both left side tires and fifteen (15) psi for both right side tires.

## 15) Engine:

### **SK Modified® Spec Engine Rules**

The only approved engine for Spec use is the Chevrolet 350. All parts for the Spec Engine must maintain manufacturers overall dimensions and weight. All Spec Engine parts must be installed as supplied, with no machining or modification except where noted. With the exception of engine machined components, all Spec Engine listed parts and components must be used as purchased, with no modifications permitted, unless otherwise noted.

#### Engine Requirements

GM BLOCK – 10066034, 3970010, 3970014, 14010207, 14010209, 14011064, 14016379 , the DART SHP, or any pre-existing GM Bow-Tie block.

The maximum decking of the block is 9.00". Angle milling of the block deck is not permitted. Offset dowel pins are not permitted. De-flashing, grinding, welding or painting of any internal area is not permitted. Maximum overbore is .060". A maximum static compression ratio of 11.0 to 1 is permitted.

## Pistons and Rods

Wiseco Pro Tru-PT003H, JE SPR- 157076, or Manley-5915 piston must be used. Manley-14104-8 or 14050R-8, or the Crower Sport Rod- SP3205 must be used.

A. The approved piston must retain all its manufactured dimensions and weight. The JE and Manley pistons must maintain a 2.50" pin length. Wiseco pistons must maintain a 3.00" pin length.

Additional gas porting of any type is not permitted. All rings must be installed, working and of magnetic steel. Stainless, z-gap, gapless, or Dykes type rings are not permitted. No portion of piston may protrude above the top of the block. The minimum ring thickness permitted is as follows:

Compression rings

.043". Oil ring assembly 3mm.

B. Only magnetic steel non-coated piston pins maintaining a minimum diameter of .927" inch are permitted. They must be contained by bushings only (no bearings of any type). Full floating pins are permitted. Wrist pins may not be coated.

C. Piston pin holes must be in a fixed location in the piston and connecting rods.

D. Only two-piece insert style connecting rod bearings are permitted.

E. The approved rod must retain all of its manufactured dimensions and weight. Only normal engine balancing and the use of after-market bolts and nuts are permitted. No deburring, de-flashing, polishing, grinding or lightening is permitted. Rod length must be 5.700".

G. Minimum weight for piston, pin, ring, bearing and rod assembly is 1168 grams.

## Oil Pan

Dry sumps, external oil pumps or tanks or accu-sump systems are not permitted. The Canton 11-196 steel pan or any pre-approved existing aluminum oil pan may be used. Oil coolers are permitted.

Only OEM, in the pan, magnetic steel type oil pumps are permitted. No pumps of any type may be used as evacuation systems.

## Heads

The Dart 10024266 cylinder head casting must be used. The casting part number must be purchased as completely produced by Dart, custom ordering of partial production/finishing is not permitted. The Dart casting is produced with, and must maintain a 60cc combustion chamber, a 2.02" intake valve and a 1.60" exhaust valve. Machining the valve guide bosses for seals and machining the gasket surfaces is permitted. The addition of screw-in studs, guide plates, valve spring seats, valve seals, poly-locks or jam-nuts is permitted. Coolant lines are permitted on the front/rear ends of the heads. Coolant lines are not permitted on the side of the head. Max Intake port volume is 177cc. Max Exhaust port volume is 71cc. Head gasket surface milling tolerance for SK Modified® is 0.00" to 0.050" from true 23.00 degrees of stock valve position. The Intake to pin measurement must be no less than 6.050". No other machining or modifications of any kind are permitted. The ports/runners, combustion chamber, the valve angle and location must remain as produced by Dart. The EGR port may be blocked off at the intake gasket area only, by use of a metal shim on one surface of the gasket. The exterior of the casting may be painted. A maximum of 2 intake mounting holes may have HeliCoils. Intake and exhaust mounting holes may not be added or relocated. Holes must take standard dimension bolts.

## Valves



The Manley intake valve 11596 (111 grams), Manley intake valve 11864 (114 grams), Manley exhaust valve 11543 (95 grams) or Manley exhaust valve 11863 (102 grams) must be used. Valve stems must have a minimum diameter of 11/32 inch. Valve lifter weight is 85 grams minimum. All parts must maintain production dimension and weight.

#### Valve Job

When cutting the valve seat angles, no stone or grinding marks are permitted above the bottom of the valve guide. All cutting in reference to the valve job must be centered off the centerline of the valve guide. Competition style multi-angle valve job is permitted. The bowl area must pass the 360 degree "ball" check (the appropriate sized ball must not fall into the guide area when rolling around on the valve stem). Intake is a .787" ball. Exhaust is a .531" ball. Surfaces and/or edges where the cutter or stone has touched must not be polished. No hand grinding or polishing is permitted on any part of the head.

#### Valve Springs and Retainers

OEM Stock type magnetic steel retainers that weigh a minimum of 30 grams (retainer only) must be used. Valve springs may be single or double springs, but must be parallel wound. Barrel wound, conical wound springs, or beehive type springs are not permitted. Double springs must have a diameter between 1.450" and 1.437". Valve springs must have an installed height of 1.650" to 1.800". Retainer locks must be magnetic steel, and must be Machine 7 degree, Super 7 degree, or 10-degree types only.

#### Crankshaft

A. The Scat Cast or Steel Crank 9-350-3480-5700, Callies Comp Star series crankshaft #SAF113-CM, or the Manley 190190 may be used. The main and rod journal sizes cannot be more than .020" under for the main and .030" under for the rod journals. Stroke must be 3.480". If you are currently converting an existing SK Engine over to the SK Spec Engine, you may use your existing GM cast or forged steel crankshaft, and it must weigh a minimum of 50 pounds and must be 3.480" to 3.495" in stroke. You must contact the NLWS Tech Staff to notify them of your intent to run this pre-existing crankshaft.

C. Machining or polishing of the crankshaft counterweights is not permitted. Normal standard engine balancing is the only acceptable modification that can be performed on this component. No painting or Teflon coating. No capping of the counterweight holes. Crankshafts must maintain the manufacturer's dimensions.

D. Minimum crankshaft weight is 45 lbs for the SCAT, Callies, or Manley crankshaft, and 50 lbs for the old style SK pre-existing crankshaft.

E. The Power Bond PB1012-ss, ATI 917260 , 917320, or the BHI CH-IBS-6-C harmonic balancer must be used.

#### Camshaft

K15 or P55 cast core camshafts must be used (Billet steel cores are not permitted). The maximum camshaft bearing journal size is 1.875" (47.5mm). Camshaft may not exceed .550" +/- .005" lift at the valve with zero lash.

#### Valve Lifters

**A.** An 842" diameter magnetic solid steel valve lifter must be used. Roller tappets, ceramic valve lifters, tool steel solid lifters, mushroom valve lifters, and any type of mechanical assistance exerting a force to assist in closing the valve and/or push rod commonly known as rev-kits are not permitted.

**B.** Valve lifters can weigh no less than 85 grams.

#### Rocker Arms

Aluminum or stainless stud mounted roller rocker arms are permitted. 7/16" studs may be used. Steel 5/16" x .080" minimum wall push rods must be used. Chevrolet must run 1.5 ratio rockers. Stud-girdles are permitted, aftermarket shaft rocker systems are not permitted. Competition Cams rocker part number 1604 will be permitted.

#### Intake Manifold

A second generation Edelbrock 7101 intake manifold must be used. There are no modifications or alterations permitted to the intake manifold. No porting, polishing, acid dipping, deburring, de-flashing, abrasive cleaning, internal painting, milling, cutting, drilling holes, enlarging bolt holes, matching of ports or welding. An NLWS supplied intake manifold must fit your engine complete with stock gaskets. All bolt holes must be in alignment and the same size as stock. Coolant lines are only approved from the water neck to the back side of heads. The maximum thickness allowed for the Intake gasket is .064". Note: NLWS Officials reserve the right to swap competitors intake manifolds as part of their routine post-race tech process.

## **SK Modified® Built Engine Rules**

#### Engine Requirements

a) Engine must be OEM cast iron V8 production block, or the Dart SHP Block. The maximum compression ratio allowed will be 11.5 to 1. Any engine found to exceed the 11.5 to 1 compression ratio limit will be deemed illegal. The only approved engine for GM is the Chevrolet 350, Ford is the 351, and Mopar is the 360. No deflashing, grinding, welding or painting of any internal area. Maximum overbore for is .030." No block may have more than two (2) cylinder sleeves installed and they must be made of cast iron material.

#### Pistons & Rods

a) Any flat-top three (3) ring round aluminum piston with three (3) rings in place is permitted. Valve reliefs for valve clearance only may be cut into the pistons. No portion of the piston may protrude above the top of the block. All three rings must be of flat magnetic steel. The minimum ring thickness is as follows: Compression Rings: 0.43 inches / Oil Ring Assembly: 3.0 mm

b) Only stock type steel rods will be permitted. All aftermarket connecting rods must be steel sportsman rods with a steel pin. Only normal engine balancing, and the use of aftermarket nuts and bolts are permitted. Billet connecting rods are not permitted. The minimum/maximum rod lengths permitted are: Minimum: 5.70 0 / Maximum: 6.250. All connecting roads of an engine must be the same length.

c) Minimum weight for piston, pin, rings, bearing and rod assembly is 1075 grams.

#### Oil Pan

i) Dry sumps, external oil pumps, or tanks or accu-sump systems are not permitted. Evac system pumps are not permitted. Windage trays will be allowed. Oil coolers are allowed outside the body. Only OEM type in-the-pan oil pumps are permitted.

#### Cylinder Heads.

a) Only stock OEM cast iron cylinder heads will be permitted.

b) Approved Cylinder Heads

i) GM stock OEM steel 492 castings, the old style 461, the old style 462, or the DART part number 10024266 cylinder head. GM Angle plug, Bow-tie or Vortec heads are not permitted.

Intake valve must be 2.02" maximum diameter. Exhaust valve must be 1.60" maximum diameter,

ii) Ford Cleveland or Windsor must use Stock OEM steel heads of two-barrel design that came on a passenger vehicle, with a maximum intake valve of 2.05" and exhaust valve of 1.66". Ford Windsor may use the cast iron "World Products Windsor, Jr." cylinder head - part number 05303B. Intake valve must be 1.94" maximum. Exhaust valve must be 1.60" diameter. This is the only approved aftermarket cylinder head.

iii) Mopar must use the stock OEM steel passenger car version of casting numbers 3418915, 4772576 or 448308 with a maximum 2.02" intake valve and a maximum 1.60" exhaust valve. Chrysler may use part 318B with a maximum 2.02" intake valve and a maximum 1.60" exhaust valve.

c) No W2 or TA heads allowed.

d) All cast lines and insignias must be clearly visible and complete.

e) The only modifications allowed will be the installation of valve guide sleeves and milling of the gasket surfaces; however, angle milling, changing the angle of the head gasket surface in relationship to the rest of the head, is not permitted. Additionally, altering the position or angle of the valve guide is not permitted. The addition of screw-in studs, guide plates, valve spring seats, option valve seals, Poly-Locks, or jam-nut devices are permitted. The machining of valve guide bosses allowed is for seals only. Coolant return lines are allowed to be placed on the ends of the heads. The following head modifications are not permitted, including, but not limited to: port matching, flow work, grinding, polishing, beading or chemical (acid) milling. No welding or sectioning. No internal modifications of any kind, including painting or Teflon coating. No more than two intake mounting holes may have HeliCoils. Intake or exhaust manifold mounting holes may not be added or relocated. Holes must take standard intake manifold bolts.

#### Valves

All valves must be identical in appearance and construction as an OEM type valve. No air directional devices will be permitted on any of the valve surfaces. Valve stems must have a minimum diameter of 11/32 inch. Stainless steel replacement valves are permitted. Hollow stem valves are not allowed. Stainless steel replacement valves are permitted. Minimum valve weights are 116 grams for the intake and 100 grams for the exhaust.

#### Valve Jobs

Three (3) angle valve jobs are permitted. When cutting the valve seat angles, no stone or grinding marks are permitted above the bottom of the valve guide. All cutting in reference to the valve job must be centered off the centerline of the valve guide. Upon completion of the valve job, the bowl area under the valve seat down to the bottom of the valve guide must still be the same configuration as far as shape and finish as it was from the manufacturer. Surfaces and/or edges where the cutter

or stone has touched must not be polished. No hand grinding or polishing is permitted on any part of the head. Un-shrouding of valves is not permitted.

#### Valve Springs & Retainers

Any type steel valve springs allowed. Double springs are permitted. Steel valve spring retainers only.

#### Crankshaft

a) Only stock production OEM crankshafts allowed. The main and rod journal size must be stock for the block being used. Original bore and stroke combination must be maintained. The maximum allowable stroke tolerance for GM and Ford will be +/- .015". Mopar will have +/- .005. Minimum main journal size .020 under stock. Minimum rod journal size .030 understock.

b) After-market crankshafts, knife-edge crankshafts, small journal crankshafts are not permitted.

c) No machining or polishing of the crankshaft counterweights allowed. Standard engine balancing is the only acceptable modification that can be performed on this component No painting or Teflon coating. No drilling of rod journals.

d) Minimum crankshaft weights are GM engines 50 lb. Ford and Mopar 541b.

e) Fluid harmonic balancers will be permitted.

f) If you are currently using an existing SK Modified engine crankshaft, you may use your existing cast or forged steel crankshaft, however, you must contact the New London Waterford Speedbowl SK Modified Technical Inspector and notify them of your intentions.

#### Camshaft & Timing Chain

a) Only magnetic steel camshafts will be permitted. The maximum camshaft bearing journal size must not be more than 1.870 inches (47.5mm).

b) Only standard production sleeve type cam bearings will be permitted and must be standard diameter for the production block being used.

c) Camshafts must be driven in the same direction of rotation as the approved standard production engine. The camshaft must maintain the same firing order as the NASCAR-approved production engine. The approved firing orders using approved cylinder identification are as follows: GM and Mopar 1-8-4-3-6-5- 7-2 Ford 1-3-7-2-6-5-4-8

d) Maximum lift at the valve with zero (0) lash is .550".

e) Any type chain will be permitted. Belt-drive and gear-drive systems will not be permitted.

f) If you are currently using an existing SK Modified engine camshaft, you may use your existing camshaft; however, you must contact the New London-Waterford Speedbowl SK Modified Technical Inspector and notify them of your intentions.

#### Valve Lifter

Stock lifter diameter must be maintained. No roller, mushroom, oversize, convex, concave or ceramic lifters. Only flat bottom magnetic steel straight barrel lifters of the same diameter and length as stock. GM Flat Tappet Lifter 0.842" x 1.88". Ford Chrysler Flat Tappet Lifter 0.904" x 1.79".

#### Rocker Arms

Roller rocker arms permitted. Rockers must be independent and stud type for GM and Ford. Stud girdles are permitted. Stock type shaft rocker system is allowed on Mopar only. Aftermarket shaft rocker systems are not permitted.

## Intake Manifold

Only the latest Edelbrock performer intake, with the Edelbrock-applied American Flag, allowed. The part numbers are Chevrolet 2101, Ford 2181, Ford 2665, Ford 2750, and Chrysler 2176. The intake must remain per manufacturer's spec out of the box. No alterations will be permitted. Older intakes with outdated part numbers are not permitted. Track supplied intake must fit your engine.

## Engine Oils

Combustion enhancing oils or additives are not permitted. Oil coolers, remote filters, and accumulators may be used. Components must be mounted securely in the engine compartment.

## **16) Cooling System:**

A stock OEM type water pump must be used. Electric pumps are not permitted. Any serpentine, cog or V-belt pulley system is permitted. Only water or Water Wetter type additives may be used in the cooling systems. Antifreeze is not permitted.

## **17) Electrical:**

### Battery

A single 12-volt Gel or Glass Mat type battery with a minimum weight of 17 lbs is permitted. The battery must be located inside the frame rails, forward of the rear end. The battery may not be inside the driver's compartment.

### Ignition System

Electronic distributors are permitted. All electronic distributors must be in stock type housings, have stock type controls and modules, be equipped with a magnetic pickup, be gear driven, and be mounted in the stock location. Billet distributor housings are permitted. Single or dual point camshaft driven distributors are permitted.

Only one ignition coil is permitted and must be mounted on the engine side of the firewall. Electronic firing module amplifier boxes are not permitted. Computerized, multi-coil, dual electronic firing module box or crank trigger systems are not permitted. Magnetos are not permitted. Adjustable timing controls are not permitted. Retard or ignition delay devices will not be permitted.

Only MSD 8727CT or 8728 External RPM limiters may be used. The violet wire must be cut back flush to the unit's housing, with the green and the white wires run directly to the coil negative, mounted on the engine side of the firewall in plain view. Accessories to regulate the power supply are not permitted. The tachometer wire must run from the distributor to the tachometer along the #8 dash bar, separate from any other wires and in an unobstructed view for inspection. The tachometer wire must be isolated from any other wires, connections or devices. The entire length of the tachometer wire must be visible from distributor to the gauge. The vacuum advance unit may be replaced with a manual non-electronic timing adjuster that does not extend more than two inches beyond the distributor housing.

#### Alternator

A functioning 12-volt single alternator system is optional.

#### Starter

A stock type starter must be used. The starter must be in stock position and operative at all times.

### **18) Exhaust:**

SK Modified® Spec Engine must use the following headers:

Flowrite: Troyer 3025, CD 3035, Raceworks 3045, Spafco 3055

Kooks: Troyer SMS1048, CD SMS1438, Spafco SMS1348, Raceworks SMS1253

Beyea Performance: AMSST-23S1-SK

Headers must remain as manufactured, no modifications are permitted. The exhaust header flange must mount directly to the cylinder head with no spacers between the flange and the cylinder head. Header flange thickness may not be altered. Inserts are not permitted in any part of the header or collector. Only one collector allowed per side.

#### Mufflers

Kooks (part# R35-30-10 or R35-35-10), Flowrite (part# FR-300 or FR-3500), or Beyea Performance (part# MUF3.5-SK) mufflers must be used. Mufflers may not be modified and must be removable for inspection. The life expectancy for all mufflers is two years. Race teams are responsible for the condition of their mufflers. Mufflers found to have deteriorated baffles due to rust/rot will be treated the same as if modified.

Turn-downs must be used after the mufflers, on each side. The turn-downs must be installed so that hot exhaust, engine debris, or engine flames are aimed towards the ground.

Thermal wrap is not permitted anywhere on the exhaust system. Only one muffler and exhaust pipe allowed per side. Interior coatings are not permitted.

### **19) Fuel System:**

#### Carburetor

Holley two-barrel model #4412 carburetor must be used. The body, base plate, metering block, and bowl must be a standard Holley 4412 part. Aluminum main bodies are not permitted.

HP parts are not permitted. Carburetors and/or carburetor components machined from billet materials are not permitted.

OEM type gaskets, jets, and power valve must be used.

The diameter of every hole in the carburetor must pass the standard New London-Waterford Speedbowl pin and tooling gauges.

The only changes allowed are:

- The choke plate and shaft may be removed, but must be permanently sealed.

- Throttle plate screws may be trimmed flush with the shaft.

Choke horn may not be removed.

Polishing, grinding, or reshaping of any part of the carburetor or metering block is not permitted.

Drilling of additional holes or plugging of holes is not permitted.

Boosters may not be changed. Booster size or shape may not be altered. Height must remain standard.

Venturi area must not be altered in any manner. Casting ring must not be removed.

Alterations to allow additional air to be picked up below the opening of the venturi such as altered gaskets, base plates, and drilling holes into the carburetor is not permitted.

Base plate must not be altered in shape or size.

Stock Holley 4412 or Stainless Steel Holley (Part# 346) butterflies must be used with Holley 4412 carburetor. Butterflies must remain as manufactured and must maintain the Holley production tolerance thickness of .0438" to .0398".

#### Carburetor Spacer

The Canton (Part# 85-065, 85-060, 85-060S, 85-065S) or the Moroso (Part# 64966) (with a maximum height of 1") may be used. The spacer may be cut out to a maximum dimension area (port hole) of 2.150" x 3.750". Straight cut only, completely through the spacer. No angle cutting, no radius on the edges, and no steps. The Big Haus USA 002 spacer may be used with no modifications. One gasket per side, maximum gasket thickness of .075" permitted. Additional openings for the induction of air are not permitted. Carburetor and spacer mounting hardware must be solid and must not permit air to pass through or by.

#### Air Cleaner/Filter

Only (1) round, dry paper, 1-½"-5" tall air filter element is allowed. The air cleaner top and bottom must be solid metal, measuring 12-14", matching the size of the air filter being used. The central hole in the air cleaner base may not have a lip. The bottom of the air filter element must measure within two inches of the carburetor's top flange. A spacer may be used between the carburetor and the air cleaner so long as the two inch specification is not exceeded. (1) 0.075" base plate gasket only. Air filters may not be sprayed or soaked with chemicals. No air boxes, ducts, baffles, or devices to control airflow are permitted on, or in the air cleaner assembly. All air entering the carburetor must pass through the air filter. A shield may be used on the front outer half of the element. No portion of the hood may be higher than the bottom of the air cleaner.

**The bottom of the air filter element must measure within 2-1/2 inches of the carburetor's top flange. A spacer may be used between the carburetor and the air cleaner so long as this specification is not exceeded. You may not compete without the air filter, air filter housing or hood in place.**

#### Fuel Shut-off Valve

A ¼ turn fuel shutoff valve is required in the fuel line with ON and OFF positions clearly labeled. The valve must be open when the handle is aiming front to back and must be closed when the handle is aiming left to right. Fuel shut-off valves must be on the passenger's side and easily accessible to emergency workers.

#### Fuel Specifications

The only approved fuel for any SK engine is Sunoco Supreme. The use of additives, catalysts, or fuel-altering devices are not permitted. Icing or cooling of the fuel system is not permitted.

### Fuel Check Safety Valve

All cars must be equipped with a fuel check safety valve. Suggested manufacture is SRI (Part# FPF-FSV).

### Fuel Cell

The use of a commercially manufactured fuel cell is mandatory. The minimum requirements for approved fuel cells are ATL Super Cell 100 Series, and Fuel Safe Sportsman Series, **and Schultz Racing Fuel Cells**. Fuel cell vent check valves are mandatory. Fuel cell containers must be colored red and made of 22-gauge (0.031") magnetic steel. Gas caps must be tethered and be identified with the car number (XX) and division (SK). **Fuel Cell MUST vent out the rear of the tail panel.**

## 20) Drivetrain:

### Flywheel and Clutch

The Quarter Master 298108 or 298158, 7-1/4" two disc V-Drive, with an SFI rated 153 tooth steel OEM type ring gear/flexplate that weighs a minimum of 4.1 pounds may be used.

### Optional Stock Type Flywheel and Clutch

A Stock OEM dimension 153 tooth steel flywheel and 10" steel clutch and pressure plate may be used. OEM type steel pressure plate and steel disc only. Solid type disc only, no paddle or button type discs. Minimum diameter 10" clutch and pressure plate. Drilling or lightening of any part is not permitted. Steel bolts only. Flat surface machining allowed only on the face of the flywheel, any cutting on the back side of the flywheel will deem the part illegal. Spec Engine flywheels must weigh a minimum of 9 lbs (without bolts) and be one of the following part numbers:

10,000 RPM 1019-9.5

Magnus MRPBF-95

Ram 851

### Built Engine Flywheel and Clutch

Flywheel must weigh a minimum of 12.5 lbs (without bolts). Pressure plate, Cover, & Solid Disc (no bolts) 16 LBS. The steel solid disc (no bolts) must maintain a minimum weight of 2.5 pounds and a maximum weight of 3.8 pounds after the combined weight has been determined.

### Bellhousing

Only a commercially manufactured magnetic steel bell housing may be used. The bell housing must enclose the flywheel 360 degrees with minimum 3/16" inch magnetic steel. Any modifications made to the bell housing must be done with 3/16" steel and welded in place (no bolt on pieces). A commercially manufactured bellhousing (like the Quarter Master 008110440) with a bolt on bottom cover may be used. An opening no larger than 3 1/2 x 4 inches may be used for throw out bearing access. This hole may be covered with sheet metal.

### Transmission

The following transmission options are permitted:

#### GM OEM Production Stock 3 or 4 Speed Transmission

OEM Stock cast iron, aluminum or magnesium transmission housings, or the Magnus part number



MRPSA-1009 housing is permitted. The OEM Stock transmission side cover must be used. Removal of first gear or replacement of first gear with a metal spacer, in 4-speed transmissions is permitted. All other forward and reverse gears must be in working order, and they must be operational from inside the driver's compartment. Only OEM type, steel, angle cut forward gears are permitted. OEM gear ratios must be used. Lightweight parts, machining, coatings, or special bearing upgrades are not permitted.

#### Richmond Two Speed

Modification of the dog-ring and slider (high gear only) in Richmond 2-speed transmissions is permitted. The following Richmond 2-speed transmission part numbers are the only approved Richmond part numbers: 7020010X, 7020026X, 7027010X, 7027026X, the X representing

Richmond's ratios letter designator. The following Richmond produced low gear ratios are the only approved ratio for use in the Richmond 2-speed transmission: 1.2250, 1.3391, 1.4588, 1.5956, 1.7442. Lightweight parts, machining, coatings, or special bearing upgrades are not permitted.

#### Jerico 2SP

The Jerico oval track 2speed transmission (part # 2SP, base model) as produced by Jerico is permitted.

The Jerico 2 speed transmission may be run, with only the following "Low Gear" options allowed: 1.2250 to 1.7100, and "High Gear" must be 1:1. No modifications or options are allowed to the base Jerico 2SP.

The addition of any optional parts (other than base model supplied/needed), and/or any lightweight parts, machining, coatings, or special bearing upgrades are not permitted.

All transmissions must have a constant engagement of the input shaft with gear and countershaft with cluster gears. High gear must have a ratio of 1 to 1 and no other gear may have a ratio higher than 1.20 to 1.

Five-speed transmissions, with gears removed, are not permitted. Quick change transmissions are not permitted. Automatic or semi-automatic transmissions are not permitted. Additional or different from OEM bearings other than the tail-shaft, which may have roller bearings, are not permitted. The transmission must be a "side shift" unit. Top shift transmissions are not permitted. Machining or lightening of any internal rotating or non-rotating parts including gears, shafts, and case are not permitted. Gun drilled transmission shafts are not permitted. Welding on any internal part is not permitted. Lightweight parts, machining, coatings, or special bearing upgrades are not permitted. The shifter and all of its components must be aluminum or steel.

#### Rear End

Only 10" ring gear and housings are permitted. Cambered rear axle housings or other cambered components will not be permitted. A tolerance of 1½ degrees of camber (positive or negative) will be permitted. Only aluminum or steel drive plates, the same thickness on the left and right side will be permitted.

Only magnetic steel axles, bearings, and axle housings are permitted. Only one-piece, magnetic steel axles will be permitted. Full floating magnetic steel double splined rear axles must be used. The axle splines must be straight cut, crown type axle splines will not be permitted. All axles must be

a minimum of 7.00 pounds, and a minimum of 1.115 outer diameter. Thermal dispersant coatings are not permitted.

Gear Rule

Straight rears may use 5.28 maximum to 4.86 minimum.

Quick Change rears may use 5.38 maximum to 4.86 minimum.

## 21) Figures:

**Figure 1:**

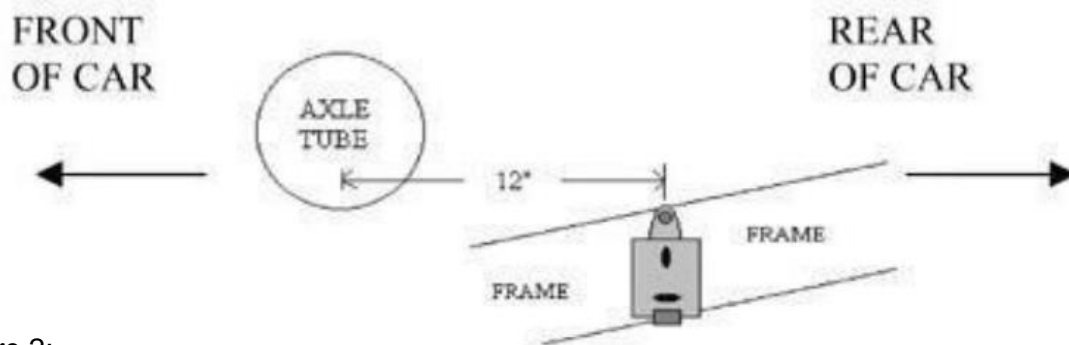

Figure 2:

