

# 2024 New London-Waterford Speedbowl Street Stock Rules

Last Updated: **1/14/24**

## 1) Introduction:

Interpretations of the rules contained herein will be the sole responsibility of authorized officials of New London-Waterford Speedbowl. Their interpretations and judgments shall be final.

All equipment is subject to the approval of the New London-Waterford Speedbowl Officials.

It is the competitor's responsibility to become familiar with the Street Stock Division Rules and the New London-Waterford Speedbowl General Rules.

### Contact Information:

Joseph Delorimiere - New London-Waterford Speedbowl Technical Director

Email: [grip340@aol.com](mailto:grip340@aol.com)

Phone: 860-514-1713

## 2) Driver Eligibility:

Drivers 14 years old and up are eligible to compete in the New London-Waterford Speedbowl Street Stock division. In order to participate in any on-track activity all cars must complete a technical & safety inspection and all drivers must be signed in with all completed paperwork on file. This includes Driver Registration Form and Number Registration Form. By registering as an owner or driver you agree to be knowledgeable and bound by the contents found in these rules and in the New London-Waterford Speedbowl General Rules.

## 3) Safety:

### Racing Seat

An aftermarket, aluminum fabricated racing seat, sized correctly for the driver, must be used. See General Rules for detailed requirements.

### Seat Belts

A minimum 5-point safety harness is mandatory. Belts must be SFI rated and dated no older than 3 years from the date of manufacture. See General Rules for detailed requirements.

### Window Net

A commercially manufactured, SFI rated, nylon window net must be installed in the driver's side door window opening **and dated no older than 3 years from the date of manufacture**. See General Rules for detailed requirements.

### Fire Suppression

A fire extinguisher or fire bottle suppression system securely mounted in the car is mandatory.

See General Rules for detailed requirements.

#### Safety Gear

A double-layered, full fire suit made of Nomex material is mandatory. SFI rated gloves and shoes are mandatory. Full- face SA2005 rated or newer helmets are mandatory. A head and neck restraint system (Ex: HANS, Hutchens, or similar) is mandatory. See General Rules for detailed requirements.

#### **4) Transponders & Radios:**

All cars must have functional transponders in order to participate in any on-track activity (see Figure 1 for mounting location).

Two-way radios are not permitted. Drivers must monitor the race control frequency (464.5000) through the use of a radio scanning device and comply with all requests from race control.

One (1) rear view mirror mounted at the top of the windshield is permitted. Maximum mirror size is 14" X 2".

#### **5) Technical Rules:**

In the following rules you will see the term "stock OEM" used. This means "original equipment manufacturer". These parts must come on a standard production car.

No carbon fiber or titanium parts allowed. None of the following will be allowed in or on any engine or driveline component or part: abrasive cleaning, acid dipping, chemical milling, coating, epoxying, finishing, grinding, painting, plating, polishing, porting, etc.

Outlook Notes:

Commercially produced Sportsman body

~~2023: Permitted~~

~~2024: Permitted with 100 lbs weight penalty~~

~~2025: Not permitted~~

Front jacking bolts and outboard shocks

~~2023: Permitted with 50 lbs weight penalty~~

~~2024: Permitted with 100 lbs weight penalty~~

~~2025: Permitted with 200 lbs weight penalty~~

#### **6) Approved Models:**

Only 1978 or newer General Motors cars with a metric G-body frame are allowed.

## 7) Body, Appearance:

All body parts must retain factory-listed dimensions, lines, and angles. Body panels may be constructed from stock OEM steel or .040 Aircraft Grade Aluminum. Aftermarket ~~GM model~~ stock appearing body panels will be permitted. Commercially produced Late Model or ABC bodies are not permitted.

### Roof

Stock OEM GM roof with stock windshield lip is permitted. The windshield must fit in the stock OEM position. Cars built with a fiberglass roof must use a halo bar safety plate (see Figure 2). Roof height is 48" and will be checked in two locations: 10" back from the windshield and 6" forward from the top of the rear window.

### Windows

A full windshield made of polycarbonate material ( $\frac{1}{8}$ " minimum thickness) is required. Windshield angle must measure 30 degrees from anywhere in the center of the windshield. Quarter windows are allowed but must be made of clear polycarbonate material. If quarter glass isn't used, then the window openings must remain open. **Rear Windows are not permitted. The rear window opening may be strengthened.**

### Hood

Hoods may be fiberglass but must lay flat at the stock angle with no rear opening. The hood must be secured in the front with (3) hood pins. A maximum 2" high cowl induction hood scoop is permitted.

### Bumpers

Front and rear bumpers must be tubular. Supports may not extend past the flat surface of the tire. Bumper height center must be 18" to the ground. Aftermarket (rubber) bumper covers must be used **and must match the era/style of body being used. Example: Monte Carlo must use Monte Carlo Nose. No Camaro Noses permitted on non-Camaro bodies.** No holes are permitted in the rear bumper cover.

### Nerf Bars

Nerf bars may be used between wheel openings at hub height. Bars must be 1" round or 1" x 1" square tubing mounted tight to the body with no sharp edges, angles, or points. Nerf bar ends must be tapered or capped. Carriage type bolts must be mounted inwards. Polycarbonate rub rails are permitted.

### Front Fender

Top of the front fender and front bumper cover meeting point must measure a minimum 29" from the ground. Downforce fenders are not permitted.

### Rear Overhang

Minimum rear overhang is 40", measured from the center of the rear axle to the end of the rear bumper cover.

### Body Skirts

Side skirts are allowed between the wheel openings with a minimum ground clearance of 5". Skirts must follow the contour of the body and may not be stepped or angled. Skirts may be added to the rear quarter panels with a minimum height of 10" to the ground.

### Rear Spoiler

A 4" high by 60" wide clear polycarbonate rear spoiler may be used, measured from the top of the tailpiece or trunk lid. Station wagons may use a 2" high by 60" wide spoiler, mounted at the trailing edge of the roof panel. **1978 to 1987 Monte Carlo Bodies can use a max 5" high x 60" wide spoiler.**

### Interior Sheet Metal

All interior sheet metal must be a minimum 22 gauge (.031") **magnetic** steel. Drivers must be separated from the engine and trunk area. The front firewall must be in stock location with no foot box. The rear firewall must remain at stock angle between wheel wells. Firewalls must be welded. **No aluminum Firewalls or interior tin permitted. Dashboard may be made from aluminum.**

A full, stock appearing floor pan must be used. Right side floor pan may be installed at the same height as the transmission tunnel at no more than 3" from the top of the transmission case and 3" above the top of the right frame rail.

Filler panels must be used between the firewall, roll cage uprights, and the right and left door. These panels must be straight to the frame rails with no bends or curves.

### **8) Weight:**

All specified weight requirements are driver included. Car minimum weight must be labeled on the right A-pillar of the car.

The minimum total weight is:

2975 lbs.

3050 lbs. for cars equipped with 4 barrel carburetors.

Front jacking bolts and outboard shocks

~~2023:~~ Permitted with 50 lbs weight penalty

The maximum left side is 55.0% of the total weight.

Any car found to be under the minimum overall car weight allowance will be penalized one position for every pound under the minimum total weight.

All ballast weight must be magnetic steel or lead only, in block form, weighing no less than 5 lbs per block. Pellet weight is not permitted. Weight must be welded in a box or attached with (2) or more 7/16" minimum diameter, grade-8 bolts and locking nuts. Added weight may be mounted under the car, securely bolted or welded as high as possible, and painted white with the car number labeled in black. No added weight will be permitted inside the driver's compartment.

**No lead or ballast weight is permitted on the rear axle. All lead mounting must meet officials approval.**

## **9) Frame & Chassis:**

G-Body OEM frames must remain stock with no repositioning, elongating, or oversizing of any mounting holes in the frame. 2" x 3" x .083" magnetic steel tubing may be used to replace the frame rails from the rear spring pocket to the rear bumper. The tubing must follow stock dimensions of the frame being used. Tubing must maintain a minimum ground clearance of 11".

The center section of the frame may include tubing to form an "X".

The Johnson and Hamm's X-Y-G Metric chassis and front clips are allowed. The chassis and front clip must remain as manufactured and retain all factory GM OEM specifications including, but not limited to, mounting locations for the following components: OEM upper and lower A-frames, shocks, rear trailing arms, steering components, and engine mounts.

The Johnson and Hamm's X-Y-G Metric chassis rear clips are allowed **but will have to carry 15lbs on each side of the front clip in front of the #1 Spark Plug**. The rear upper control arm cross members may be installed.

### Roll Cage

1- $\frac{3}{4}$ " diameter x .095 HREW or DOM steel tubing is mandatory for all roll cage bars. A magnetic steel anti-intrusion plate made from a minimum thickness of .080 must be securely welded to the outside of the left side door bars. All cars must have a foot protection bar located at or in front of the pedal assembly. All roll cage, foot protection bar, and anti-intrusion plate joints must be suitably and appropriately welded by competent craftsmen. See General Rules for roll cage, foot protection bar, and anti-intrusion plate detailed requirements.

### Fuel Cell Crash Bar

A reinforcement bar made of 1- $\frac{1}{2}$ " X 0.083", must extend below the rear frame section behind the fuel cell. This bar must be as wide as the rear frame rails and extend as low as the bottom of the fuel cell with two vertical uprights, evenly spaced between the frame rails, and attached to the rear cross member. Two support bars (one located on each corner) must angle upwards and be welded to the rear frame rails.

## **10) Ground Clearance:**

Minimum ground clearance for chassis, body, and nose piece is 5". All ground clearance requirements will be measured with the driver in the car.

## **11) Track Width:**

Maximum allowable track width is ~~74"~~ **73 1/2"**, measured at wheel center height from the left outside bead seat to the right outside bead seat.

## 12) Wheelbase

Wheelbase must measure 108" +/- 3/8", measured from the center of the rear axle to the center of the front, lower ball joints.

## 13) Suspension:

### A-Frames

Upper and lower A-frame bushings may be replaced with polyurethane bushings. Hole locations may not be altered.

### Upper A-Frames

Stock upper A-frames must be unaltered. Any steel, tubular, replacement control arms with steel cross shafts are allowed. Control arm must fit the stock 6-7/8" perch or stock replacement. Upper ball joints must be stock OEM.

### Lower A-Frames

Stock OEM lower A-frames must be unaltered. Offset control arms will not be permitted. Aftermarket G-Metric replacement or Johnson Chassis lower A-frames (Part# JCI-09-02-01) are permitted (stock length).

Lower ball joints must remain in stock location. Moog screw-in ball joints (Part# K727) or equivalent part # are allowed. Low friction ball joints are not permitted. Rebuildable ball joints are not permitted.

### Coil Springs

Front and rear steel racing springs are allowed and must measure a minimum 5" in diameter. Springs may use spring spacers and adjusting cups.

Front springs must be in the stock location.

Spring cups on the axle tube may be replaced but must remain in stock location on the axle tube. Offsetting of the cup is not permitted. Rear jacking bolts are permitted.

### Front jacking bolts and outboard shocks

2023: Permitted with 50 lbs weight penalty

### Shocks

Front and rear shocks must be a matched pair, left to right. Shocks must test according to the manufacturer's specifications.

Rear shocks may be placed on top of the frame in the original position (must use original mounting holes) with maximum 1-1/2" spacers. Front shocks may use maximum 1" spacers at the lower mount.

### Approved shocks:

Front: KYB **KG Series** KG4513, Pro **SS Series** SS100, Afco **10 Series** 1020, Afco 1021, Afco 1022, QA1 EC1956P, QA1

23946M, Bilstein **AK Series** AK1043. Afco 14 Series, Pro WB Series.

Rear: KYB **KG Series** KG5548, Pro **SS Series** SS201, Pro WB Series, Afco 14 Series, Afco **10 Series** 1030, Afco 1031, Afco 1035, QA1 EC1685P, QA1 23685M, Bilstein **AK Series** AK1044.

### Sway Bar

The front end sway bar must be stock GM OEM or stock GM OEM replacement. The sway bar must be magnetic steel, one piece, and can be no larger than 1-3/8" in diameter. Modifications to the sway bar are not permitted. Front sway bar must mount under the frame, in the stock location, and attach to the lower A-frame in the stock location. Bump pad configurations are not permitted. Rubber sway bar bushings may be replaced with metal bushings or eye/lollipop type mounts. Howe bars, etc. are not permitted. Link pins may be replaced with threaded rod and Heim joints. Rear sway bars are not permitted.

### Spindle/Hub

Spindle may be changed to heavy duty OEM units. They must be bolt-on units and not be altered in any way except the lower ball joint hole may be reamed or tapered to fit the lower ball joint pin. No aluminum spindles. Hub/rotor must be stock OEM. Coleman safety hub is permitted on both sides.

### Bearings

All bearings (wheel, differential, and transmission) must be of stock OEM design. Bearings may be either angle-type cone, straight barrel-type, or ball bearing. All bearings, including the rollers, must be magnetic steel. Bearing spacers may be used with wheel bearings. No REM machined bearings or micro-polished bearings.

### Trailing Arms

Lower trailing arms must be stock GM OEM and unaltered. Upper trailing arms may be slotted or cut and welded but must be within 1" of stock length and must be centered. Mounting holes and locations must remain stock OEM (see figure 3). Johnson Chassis (Part# JCI-09-03-04 & JCI09-03-03B) or Speedway Motors (Part# 91634052 & 91634054) upper and lower trailing arms may be used. Trailing arm bushings must be stock OEM or polyurethane OEM replacement. Offset bushings are not permitted.

### Suspension Tie Downs

Tie downs or limiting devices are not permitted on the front suspension. Rear suspension devices must allow the frame rail to be raised a minimum of 4" before the rear tires come off the ground.

## 14) Steering:

The steering linkage and steering box must remain stock GM OEM or stock GM OEM replacement. The steering shaft may be removed from the column and securely reinstalled with Heim joints. OEM tie rod adjusting sleeve may be replaced with threaded magnetic steel tubing with jam nuts. No aluminum components.

Bump steer correction center link may be used. Idler arm holes on the chassis may be slotted or an adjustable stock dimension idler arm may be used. The forward most bolt hole on the chassis for the steering box must remain unaltered. The (2) rearward bolt holes may be slotted.

### **15) Brakes:**

Brake systems must be stock OEM hydraulic systems. All (4) brakes must be in working order. Drilling or lightening of any brake parts including backing plates, shoes, or pads is not permitted. Aftermarket master cylinders and pedals are allowed. Adjustable proportioning valves are allowed (front to rear adjustment only). Braided stainless steel brake lines are permitted.

Ultra Cool (Part# LMBFS5-625 L or R) hub mounted cooling fans may be used on ~~front brakes~~ **all 4 wheels**. (one per wheel).

Howe GM aftermarket caliper (Part# HOW337 or HOW33658) is allowed (must have Howe logo). Capitol Motorsports alternative caliper (Part# LHC258 or LHC21516) is allowed. Rear disc brakes are allowed. Stock G-Body Metric calipers only. Calipers must be mounted in the same position left to right side. Steel caliper slider pins only. Caliper brackets must be steel and may be welded or bolted to the housing tubes or tube flanges.

Speedway Motors rotor (Part# 91031043) or aftermarket dimensionally equivalent rotors made of the same material and weight are the only allowed rotors. Maximum rotor diameter is 11.630". Rotors can not be lightened, drilled, scalloped, or slotted in any way.

### **16) Wheels:**

All (4) wheels must be heavy-duty, aftermarket, steel wheels. All wheels must be 15" x 8". Minimum wheel weight is 19 lbs. 1" lug nuts and ½" wheel studs are mandatory. No "bleed off" type valve stems. Metal wheel spacers may be used but must be equal thickness, left side to right side. (1) ½" maximum thickness wheel spacer allowed per wheel.

### **17) Tires:**

Hoosier Tire East will be the sole supplier of tires for the Street Stock division. The sizes are 26.5 / 8.0 - 15.0 or 27 / 8.0 - 15.0. The compound is 970. Tires must be considered identifiable.

### **18) Engine:**

The only approved engine is the GM Performance Factory Sealed Circle Track 602 (Part# 19258602 or 19434602). Engines must be purchased directly through General Motors or an authorized service center.

Seals may only be removed by a New London-Waterford Speedbowl official or a New London-Waterford Speedbowl authorized service center. Any seals that appear to have been tampered with or have been removed without one of these two parties being present will result



in the engine being deemed illegal. At which point the engine must be re-sealed at the participant's expense.

Rebuilding of crate engines is not allowed. Repairs may be made with authorization from the Technical Department. A New London-Waterford Speedbowl technical inspector must be present when seals are removed. After repairs, the engine will be re-sealed. A fee will be assessed for engine re-sealing.

Note: All engines must be sealed and documented to compete at New London-Waterford Speedbowl. A complete crate engine registration form must be completed and submitted to New London-Waterford Speedbowl Officials. **No Alliance Sealed 602 Crate Engines are permitted. The New London Waterford Speedbowl does not participate in the RPM Seal Alliance Program.**

Authorized crate engine service centers:

Nat's Racing Engines; Swansea, MA

RAD Auto Machine; Ludlow, MA

T/A Engines; Plainville, CT

Performance Engines; Torrington, CT

Pettit Racing Engines; New Milford, CT

Larry's Auto Machine; Groton, CT

Automachine LLC; East Windsor, CT

Andy's Auto Machine; Plainville, CT

Engine Location

Engine must be in the stock location which is where the distance between centerlines of the forward most fuel pump to engine block mounting bolt and the upper idler arm to frame mounting bolt measures 8.75" +/- .25" with all bolt holes being in the stock OEM location. The minimum crankshaft height is 13", measured from the centerline of the crankshaft to the ground. Steel replacement engine mounts are permitted.

Engine Oils

Combustion enhancing oils or additives are not permitted. Oil coolers, remote filters, and accumulators may be used. Components must be mounted securely in the engine compartment.

### **19) Cooling System:**

Radiators must remain in the stock OEM location. An electric radiator fan is permitted. All cars must be equipped with a minimum (1) gallon overflow container. Only water or Water Wetter type additives may be used in the cooling systems. Antifreeze is not permitted. Only stock OEM steel water pumps are allowed.

### **20) Electrical:**

Battery

Only a single 12-volt OEM automotive type or an automotive type gel-battery is permitted. The battery must be located inside the frame rails, forward of the rear end. The battery may not be

inside the driver's compartment. The battery must be held in place with a metal crossbar and two threaded rods, welded or bolted to the chassis or roll cage. The positive cable of the battery must be inside the frame rails.

A battery cutoff switch must be present in the passenger's side area of the car. The switch must be within reach of the driver and accessible to safety crews.

#### Ignition System

Only stock OEM-type HEI distributors, using the factory production firing order, are permitted. Only stock-type coils are permitted. Coil must be located inside the cap. No MSD or super coil-type coils. The only aftermarket part allowed in, or on, the complete distributor will be advanced springs.

All ignition systems must be equipped with a working MSD rev limiter (Part# 8727CT). Rev limiter must be mounted on the firewall, on the engine side, with all wiring visible. Maximum engine RPM must be set to 6,400 RPM. An advanced lock kit may be installed in place of the advance assembly.

#### Spark Plugs

Spark plugs must match the type of head being used. The gasket-type head must use the gasket seat spark plug. The tapered-type head must use the tapered seat spark plug.

### **21) Exhaust:**

Unmodified "log type" manifolds may be used. Silver Seal (Part# 6553) manifold adapter plate may be used on the right side exhaust manifold. Medieval Chassis exhaust manifold adapter plate (Part# MMXLT1-100 LT1) may be used. Engine may match the exhaust manifold port to the cylinder head. The maximum depth into the top of the exhaust manifold is 1-1/2". The maximum depth into the bottom of the exhaust manifold is 1/2". No blending is permitted beyond these points. The remainder of the manifold must remain unaltered. The maximum exhaust manifold outlet diameter is 2-1/2". Chevy II, Vortec truck type, T/A, and Ram Horn manifolds are not permitted.

Engines equipped with a 2 barrel Holley 4412 carburetor may use Schoenfeld 185 headers.

Mufflers are mandatory and must be in good condition with complete baffles. Moroso (Part# 94050), Dynomax (Part# 24215), and Summit (Part# SUM-630853) are the only mufflers permitted. Only (1) muffler per exhaust pipe. The end of the muffler must be located 6" from the end of the exhaust system. The exhaust system must extend 6" beyond the driver's seat and remain under the car. The last 6" of the exhaust system must be turned down. Both exhaust pipes may exit out the right side of the car. No merging of pipes. Mufflers must be removable for inspection. Mufflers must remain complete with ends as manufactured. Check valve tubes are not allowed in any part of the muffler. Interior or exterior coatings are not permitted. The life expectancy for all mufflers is (2) years. Race teams are responsible for the condition of their

mufflers. Mufflers found to have deteriorated baffles due to rust/rot will be treated the same as if modified.

Exhaust systems may only be fabricated with 2-½" O.D. magnetic steel exhaust pipe. Stainless steel exhaust is not permitted. Maximum 2' sections (1 per bank) of 2-½" flex pipe may be used on the exhaust system. Heat wrap is not permitted on any part of the exhaust system.

## 22) Fuel System:

### Carburetor

Holley two-barrel model #4412 carburetor may be used. The body, base plate, metering block, and bowl must be a standard Holley 4412 part.

Holley 650 CFM 4-Barrel (Part# 80541) carburetor may be used with engines equipped with exhaust manifolds. The body, base plate, metering block, and bowl must be a standard Holley 80541 part.

HP parts are not permitted. Carburetors and/or carburetor components machined from billet materials are not permitted. **No aluminum main bodies allowed.**

OEM type gaskets, jets, and power valve must be used.

The diameter of every hole in the carburetor must pass the standard New London-Waterford Speedbowl pin and tooling gauges.

The only changes allowed are:

The choke plate and shaft may be removed, but must be permanently sealed.

Throttle plate screws may be trimmed flush with the shaft.

Choke horn may not be removed.

Polishing, grinding, or reshaping of any part of the carburetor or metering block is not permitted.

Drilling of additional holes or plugging of holes is not permitted.

Boosters may not be changed. Booster size or shape may not be altered. Height must remain standard.

Venturi area must not be altered in any manner. Casting ring must not be removed.

Alterations to allow additional air to be picked up below the opening of the venturi such as altered gaskets, base plates, and drilling holes into the carburetor is not permitted.

Base plate must not be altered in shape or size.

Stock Holley 4412 or Stainless Steel Holley (Part# 346) butterflies must be used with Holley 4412 carburetor. Butterflies must remain as manufactured and must maintain the Holley production tolerance thickness of .0438" to .0398".

Stock Holley 80541 butterflies must be used with the 80541 carburetor.

Butterflies may not be thinned or tapered. Idle holes may be drilled in butterflies. Screw ends may be cut even with the shaft but screw heads must remain standard.

Throttle shaft must remain standard and must not be thinned or cut in any manner.

### Carburetor Spacer

(1) carburetor spacer/adaptor with a 1" maximum height, made of solid material, is allowed on engines equipped with a 2-barrel carburetor. Canton spacer (Part# 85-065 and 85-060) and

HVH Super Sucker Spacer (Part# SS4412-2AL) are the only permitted spacers. No modifications of any kind that direct or redirect air flow or allow additional air into the engine are permitted. Only (1) gasket 0.075" thick per side of the spacer is permitted.

Carburetor spacers are not permitted on engines equipped with a 4-barrel carburetor. Only (1) gasket 0.075" thick is permitted.

#### Air Cleaner/Filter

Only (1) round, dry paper, maximum 4" tall air filter element is allowed. The air cleaner top and bottom must be solid metal, measuring 12-14", matching the size of the air filter being used.

Spacers between the carburetor and air cleaner base plate are not permitted. (1) 0.100" inch base plate gasket only. Air filters may not be sprayed or soaked with chemicals. No air boxes, ducts, baffles, or devices to control airflow are permitted on, or in the air cleaner assembly. All air entering the carburetor must pass through the air filter. A shield may be used on the front outer half of the element. Air cleaners must remain under the hood.

#### Fuel Pump

(1) Mechanical, stock-type diaphragm pump is permitted in the stock location.

#### Fuel Shut-off Valve

A ¼ turn fuel shutoff valve is required in the fuel line with ON and OFF positions clearly labeled. The valve must be open when the handle is aiming front to back and must be closed when the handle is aiming left to right. Fuel shut-off valves must be on the passenger's side and easily accessible to emergency workers.

#### Fuel Specifications

Sunoco Race Fuel 260GTX and 93 octane super unleaded automotive pump gasoline are the only fuels permitted in the Street Stock division. These two fuels may be mixed together. The 93 octane super unleaded automotive pump gasoline must be purchased from a retail outlet and must contain a minimum of 7 percent and a maximum of 10 percent of ethanol. The use of additives, catalysts, or fuel-altering devices are not permitted. Nothing may be placed in the fuel line except a standard fuel filter. Icing or cooling of the fuel system is not permitted.

#### Fuel Cell

The use of a commercially manufactured fuel cell is mandatory. Fuel cell vent check valves are mandatory. Fuel cell must be mounted using 1" x 1" x 0.083" square tubing. See General Rules for detailed requirements. Fuel cell containers are mandatory and must be made of 22-gauge (0.031") magnetic steel. The fuel cell must be a minimum of 10" off the ground. Gas caps must be tethered and be identified with the car number (XX) and division (SS). **Fuel Cell MUST vent out the rear of the tail panel.**

### **23) Drivetrain:**

#### Bellhousing

The blow shield must be fully enclosed, commercially manufactured, and 100% steel.

### Clutch & Flywheel

Flywheel must be GM (Part# 14088646) or an aftermarket version of the OEM flywheel, made of the same material, design, and weight. Flywheel minimum weight is 14.5 lbs. Pressure plate minimum weight is 13 lbs. Clutch disc minimum weight is 2.5 lbs.

### Transmission

Only OEM production stock 3 & 4 speed transmissions will be permitted. All internal parts must be stock. Gear ratio must be of stock OEM production. Machining or lightening of any internal rotating or non-rotating parts including gears, shafts, and case is not permitted. Gun drilled transmission shafts are not permitted. Welding on any internal part is not permitted. Thermal coatings or REM type processes are not permitted. Auxiliary, over or under drive transmissions are not permitted. High gear must have a ratio of 1:1 and no other gear may have a ratio closer than 1.35:1. Aluminum transmissions are permitted. Aftermarket stock-type shifters are permitted.

### Rear End

Rear ends must be stock OEM. Differential may be open or locked using a mini spool or conventional spool. Limited slip or locker carriers are not permitted.

GM rear ends must be 7-½" 10 bolt or 8" 12 bolt assembly. A steel Ford 9" housing and differential, dimensionally equivalent to the GM 7.5" axle assembly may be used. Full floating hubs on the Ford 9" housing is permitted. All shock and control arm mounts must be in the same location as the factory GM 7.5" axle assembly. Maximum width of the housing is 58". Offset housings or cambered housing are not permitted. Racing axles (28 or 31 spline) may be used but must retain all stock dimensions. Only OEM Ford type bolt-in axles are permitted. Tube axle seals are permitted. Light weight gun drilled axles are not permitted. A heavy duty axle must be used in the right rear. C-Clip eliminators are permitted. OEM cast iron Ford center section (chuck) with OEM Ford open differential only. Locking, welding, or binding of spider or side gears are not permitted. The only components that may be replaced in the center section (chuck) assembly with non OEM Ford parts are the ring and pinion, bearings, and thrust washers. Aluminum or billet steel components in the center section (chuck) assembly, including the drive yoke, are not permitted. Aftermarket gears are permitted but must be steel and in the same design and of the same appearance as OEM. REM finished or micro polished gears, bearings, or components are not permitted. Thermal coatings are not permitted. Aluminum hubs are not permitted.

Drive shaft ~~minimum length is 50-¾"~~ Minimum tube size is 2-½" O.D. Must be made of magnetic steel and painted white.

### **24) Figures:**

Figure 1:

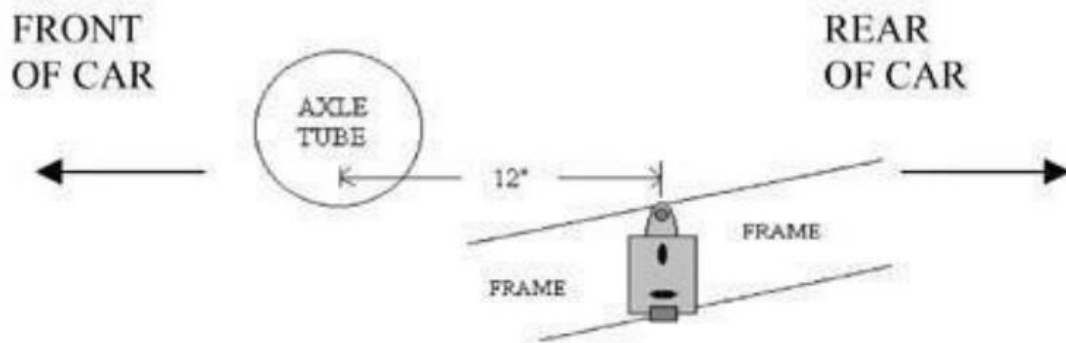

Figure 2:

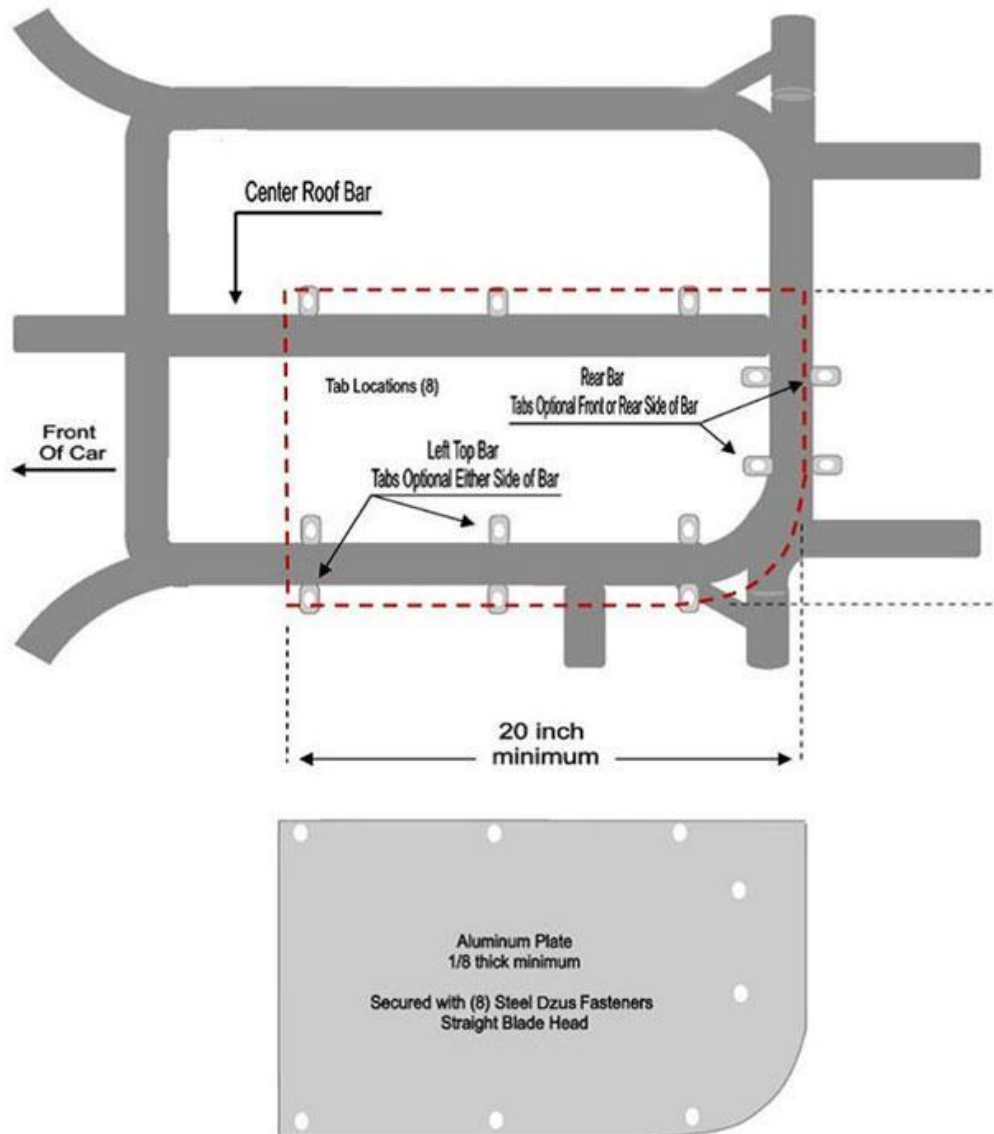

Figure 3:

