

2026 New London Waterford Speedbowl SK Modified® Rules

For any technical questions, please thoroughly read these rules and any applicable NWMT rules, then email tech@speedbowlct.com.

2026 Rule Changes

20E- 5.5.4 OIL PAN

20E- 6.5.1 Thompson Speedway Sunoco Modifieds (NLWS Specific)

20E- 10.4 TRANSMISSION (NLWS Specific)

20E – 12.1 COIL SPRINGS (NLWS Specific)

20E – 10.8 Tires (NLWS Specific)

PREFACE

The rules herein shall refer to New London Waterford Speedbowl as “NLWS”. These rules are intended to create safe, affordable, and fair competition. While they offer a good outline, every item cannot be covered by a written rule. If you have questions regarding something not detailed in these rules, please consult an NLWS Official for clarification before proceeding. These rules are for NLWS only with no expressed or implied agreement with any other speedway or series as to their interpretation, implementation and method of inspection by their technical inspectors and officials. No car, component or equipment will be considered as having been approved by reason of having previously passed through inspection unobserved. No car, component or equipment will be considered as having passed inspection for the event until the finish is made official.

The SCD, steering coupling device, manufactured by LaPlante Racing Products, www.laplanteracingproducts.com is approved

All equipment is subject to the approval of NLWS Officials. You may be assessed penalties including but not limited to: added weight, fines, loss of points, loss of handicapping, or suspension for car parts, components, and/or equipment deemed as not in compliance with these rules. Any car part, component, and/or equipment which does not conform to specifications or tolerances contained in the 2026 rule book or is not otherwise approved by NLWS may not be used in competition in 2026.

By engaging in competition at NLWS, you hereby agree to have read the 2026 NASCAR Whelen Modified Tour (NWMT) Rulebook, the NASCAR Weekly Racing Series (NWRS) Rulebook, the NLWS General Rulebook and the NLWS SK Modified® Rulebook.

All 2026 NASCAR Whelen Modified Tour (NWMT) rules and the 2026 NASCAR Weekly Racing Series (NWRS) rules, where applicable, will be enforced for the NLWS SK Modifieds®, with the following changes and/or additions (EIRI).

NLWS Officials decisions regarding rules are final and non-appealable.

DRIVER ELIGIBILITY – All drivers must have a New London Waterford Speedbowl Registration on file to compete in the SK Modified®. Drivers competing in the SK Modified® division at NLWS may cross-compete in the Late Model Division and INEX Legends only. Drivers must be at least 16 years of age.

20E- 1.3 APPROVED COMPETITION MODELS– Approved model bodies are listed in the NASCAR Rulebook. Other models both domestic and foreign steel passenger cars may be approved for the SK Modified® division providing they are the same in body configuration and meet the spirit and intent of competitive racing in the SK Modified® division.

Detailed chassis, body and interior tin rules can be found in the NWMT rule book. Body alterations / deviations from the NWMT rulebook, other than listed here, are not permitted. The decision of NLWS Officials is final and non-appealable.

You may not compete without the roof, windshield, hood, air filter or mufflers in place. Additionally, the bumpers and all nerf bars must be adequately secured to the chassis at all times. NLWS Officials will pass judgment on any body / bumper / nerf bar damage prior to continuing an event. Their decisions are final and non-appealable.

20E- 2.2 OVERALL CAR WEIGHT – All specified weight requirements will be with the driver. The minimum weight at all times will be 2,645 pounds. MOPAR engines over 359 cubic inch displacement must add 6.8 pounds per cubic inch over 359. No car will be allowed to have more than 56% of the total weight as the left side weight. Proper bore & stroke for engine type must be maintained. Any car found to be under the minimum overall car weight allowance will be penalized one position for every pound under the minimum total weight.

20E- 2.3 ADDED CAR WEIGHT – Added weight must be in block form magnetic steel or lead only of no less than five (5) pound blocks (no pellets). Added weight must be securely bolted to the frame rail and painted white with the car number stenciled in black. No added weight will be permitted inside the driver's compartment. Weight must be welded in a box or attached with two or more "grade 8" bolts minimum 7/16" diameter.

It is the team's responsibility to inspect their lead mounting on a regular basis. Cars that have lead come off their car will be assessed (at a minimum) a \$500 safety violation fine.

20E- 2.4 CAR WEIGHTS AFTER RACE – Nothing may be added to or taken from the car to make total or left-side weight. Gas, oil or water may not be added. Wheels and tires cannot be changed, but an amount equal to one half of one percent (.5%) of the gross weight will be added for loss in weight due to race wear (minimum post-race weight of 2632 lbs.). Any car found to be under the minimum overall car weight allowance will be penalized one position for every pound under the minimum total weight.

20E- 3.1 NOSE PANEL / AIR INTAKE OPENING

A conventional aluminum nose panel must be used.

The nose panel assembly must maintain 2" of ride height clearance.

The nose panel must consist of a bottom tray, two side panels, and a top panel.

Additional panels to aid in air directional flow may be installed in the nose panel.

Any additional air directional flow panels may not extend outward from the air intake opening or any part of the nose panel.

The nose panel may be no wider than the frame rails it attaches to.

The bottom tray may not extend rearward past the harmonic balancer.

The nose panel may not extend forward beyond the rear edge of the front bumper tubing. The top and bottom panels must attach flush to the side panels.

The top panel must have an air intake opening with a minimum of 165 square inches.

A metal mesh screen may be installed in or behind the air intake opening for debris protection. A flat horizontal air dam (splitter) may be installed on the bottom forward lip of the nose panel.

The air dam may be no wider than the nose panel and may extend forward a maximum of 1" from the bottom tray.

The air dam may not extend forward beyond the rear edge of the front bumper tubing.

20E- 3.2.3 SIDE WINDOW GLASS/WINDOW NET – A nylon window net must be installed in the left side door window opening, and it must be positioned to cover the entire window opening. Window net should not be used beyond three (3) years from the date of manufacture. The window net must be rib type, made from minimum $\frac{3}{4}$ inch, maximum one (1) inch wide nylon material with a minimum one (1) inch and a maximum 2-1/4 inches square opening between the ribs. The minimum window net size must be 22 inches wide by 16 inches high. All window net mounts must be a minimum $\frac{1}{2}$ inch diameter solid steel rod on the bottom and a minimum one (1) inch wide by 3/16 inch thick flat steel or a minimum $\frac{1}{2}$ inch diameter solid steel rod on the top, with mounts welded to the roll cage. The window net, when in the closed position, must fit tight and be secured with a lever-type quick release latch acceptable to NLWS Officials. The lever must be secured by a detent ball in the lever and may be supplemented by Velcro® fastener only – pins or clips will not be permitted. The latch must be mounted at the top in the front to roof bar (#3) release from the inside.

WINDSHIELD – A flat windshield is mandatory, per the NWMT rulebook, made of a minimum of 1/8" polycarbonate that extends from the left A-pillar to the #4A center windshield bar and from the roof to the cowl. A minimum of three Dzus type fasteners must be used on each of the four sides.

20E- 3.2.5 REAR VIEW MIRROR – One (1) rear view mirror must be mounted at the top of the windshield. If running a head and neck restraint system, you may run a 14" X 2" mirror. If not, the mirror must be no larger than 8" X 2". No multi-image or side mirrors. Oversized mirrors maybe blacked out by the use of paint only, to obtain the 8" X 2" maximum reflective area. Spot mirrors of any size/type are not permitted.

20E- 3.5 DOORS and QUARTER PANELS– may be made of magnetic steel or aluminum.

Right Side panels: The top and bottom Door flange must match the top and bottom Quarter panel flange, creating one line/plane when viewed from the side and above.

Left Side panels: one angle or break is permitted at the door / quarter panel seam.

All Doors and Quarter panels must be flat or convex in shape, they may not be concave. The bottom flange of the Door and Quarter panels must face inward / inboard.

The Door panels must maintain a 2" minimum ground clearance.

The Quarter panels must maintain a 7-1/2" minimum ground clearance.

Aluminum crush panels must be installed per the NWMT rulebook.

ROOF POSTS- The front roof posts may be aluminum or clear lexan. They may not be any higher than the line created from the roof attaching point to the forward most door attaching point.

The rear roof posts must be aluminum and may not be any higher than the line created from the roof attaching point to the rearward most attaching point on the quarter panel. The rear roof posts must be a minimum of 49" apart when measured across the car from left to right and may not be inboard of the rear spoiler mounting area.

The general shape and any cutouts in the rear roof posts must match from left side to right side. A $\frac{3}{4}$ " maximum top lip is permitted on the rear roof posts, and must face inboard.

REAR SPOILER- The spoiler must be 8" tall x 48" wide x ¼" thick clear polycarbonate. The rear panel must be no wider than 60" when measured across from left to right. The height of the top of the rear panel must be between 32" and 36". The rear spoiler must be mounted to the top of the rear panel, aft edge, and must be centered across the back panel.

20E- 3.7 NOSE PANEL AIR INTAKE OPENING-

The top panel must have an air intake opening with a minimum of 165 square inches.

The air intake opening must be rectangular in shape.

A metal mesh screen may be installed in or behind the air intake opening for debris protection.

A flat horizontal air dam (splitter) may be installed on the bottom forward lip of the nose panel. The air dam may be no wider than the nose panel and may extend forward a maximum of 1" from the bottom tray.

The air dam may not extend forward beyond the rear edge of the front bumper tubing.

INTERIOR SHEET METAL – The rear center panel (over the fuel cell) should be made of magnetic sheet steel, 22 gauge, .031" thick, with a minimum width of 28", and must extend from the rear vertical panel forward to the #7 roll bar, per the NWMT rulebook.

20E- 3.8 HOODS / ROOF-

C. All roof panels must be made of magnetic sheet steel, or be an NLWS approved manufactured fiberglass roof panel. All cars utilizing an approved fiberglass roof must install the (minimum) 1/8" thick aluminum anti-intrusion plate in the roll cage halo as described in the following diagram. For additional specifications on letters A. B. D. E. and F. see the NWMT rulebook. Cars may not compete without a roof or a hood.

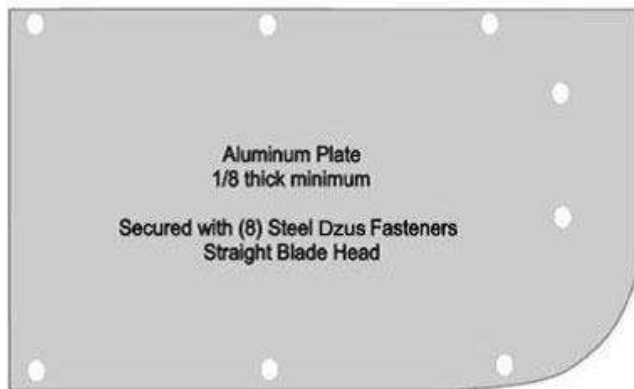
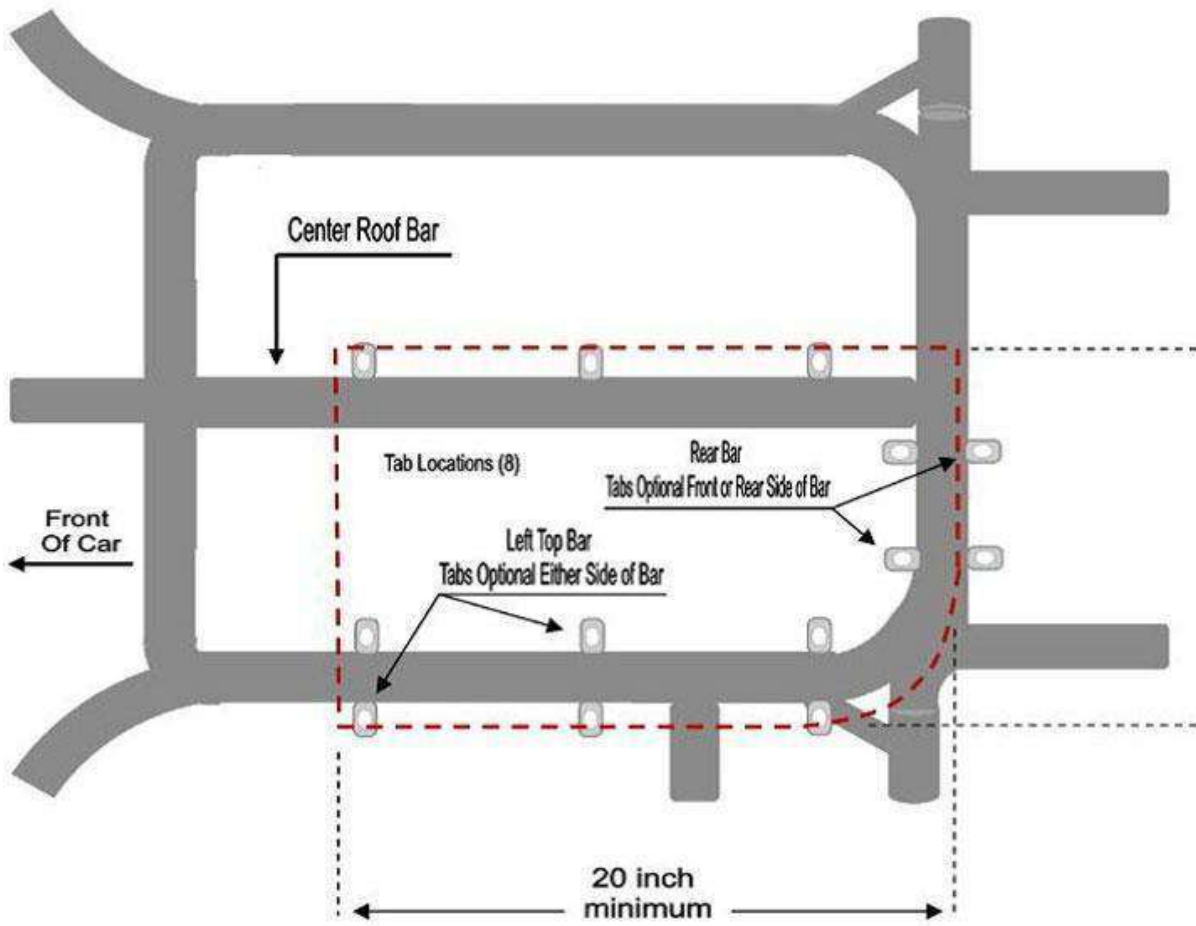

20E- 3.11 IDENTIFICATION – All car number configuration and design is subject to approval by NLWS Officials. Only single or double-digit numbers will be permitted. The size, color, and style of numbers must be adequate to permit prompt identification by NLWS Officials at all times. Numbers must be solid color, at least 18 inches high, measured vertically, excluding borders and silhouettes, must be neatly attached to or painted on both sides of the car on the center of the door. Door numbers must be a minimum of four (4) inches in width, and slant no more than 30 degrees from vertical. The tops and bottoms of all numbers must be even (not staggered). Two (2) digit numbers must not overlap and must have a minimum of ¾ inch separation. A solid number 18 inches high, excluding borders and silhouettes, must be neatly attached to or painted on the roof, reading from the passenger side. A solid number a minimum of 12 inches high, excluding borders and silhouettes reading from the passenger side neatly attached to or painted at a 45 degree angle on the right front corner of the roof is also acceptable. Solid numbers, as large as possible, must be attached to or painted on the right outer nose and taillight covers. The use of number decals is acceptable if NLWS Officials determine that the number is legible. Numbers, lettering, and paint schemes that utilize mirror or foil must be pre-approved. All schemes and colors are subject to NLWS approval.

NEW LONDON WATERFORD SPEEDBOWL SK MODIFIED® SPEC ENGINE RULES

These NLWS Spec Engine rules are intended and designed to create a standardized rule package to reduce cost, increase the level of competition, and to promote a better technical atmosphere by involving the engine builders in the process of technical inspection. To help keep the full integrity of the Spec Engine program intact, any published engine builder whose engine finishes in the top three may be involved in the tech process.

20E- 5 GENERAL SPEC ENGINE REQUIREMENTS- The only approved engine for Spec use is the Chevrolet 350. All parts for the Spec Engine must maintain manufacturers overall dimensions and weight. All Spec Engine parts must be installed as supplied, with no machining or modification except where noted. These NLWS Spec Engine rules are intended to create a standardized rule package to reduce cost and increase the level of competition. With the exception of engine machined components, all Spec Engine listed parts and components must be used as purchased, with no modifications permitted, unless otherwise noted. We will add a list of Spec Engine component part numbers.

DETAILED SPEC ENGINE REQUIREMENTS-

All Spec Engines must use the following parts, approved part numbers are as follows:

GM BLOCK – 10066034, 3970010, 3970014, 14010207, 14010209, 14011064, 14016379 , the DART SHP, or any pre-existing GM Bow-Tie block.

PISTONS- Wiseco Pro Tru-PT003H, JE SPR-157076, or Manley 5915 must be used. The ring package used (type and thickness) must be the one designed for the piston used.

RODS- Manley-14101-8, 14050R-8, 14037rNLWS-8, or Crower Sports Rods-

SP3205 OIL PAN – Any pre-approved aluminum pan or Canton 11-196, ***Moroso***

21333 VALVES- Manley Intake 11596 or 11864, Manley Exhaust 11543 or 11863

CRANK- Scat Cast or Steel – 9-350-3480-5700, Callies Comp Star Series #SAF113-CM, or Manley 190190.

INTAKE- Edelbrock 7101

Carb Spacer- Big Haus USA part 002

HARMONIC BALANCER- ATI 917260 or 917320 or BHI CH-IBS-6-C or Power Bond PB1012-SS.

The maximum decking of the block is 9.00". Angle milling of block deck is not permitted. Offset dowel pins are not permitted. De-flashing, grinding, welding or painting of any internal area is not permitted. Maximum overbore is .060". A maximum static compression ratio of 11.0 to 1 is permitted.

20E- 5.5 PISTONS/RODS

Wiseco Pro Tru-PT003H, JE SPR- 157076, or Manley-5915 piston must be used. Manley-14104-8 or 14050R-8, or the Crower Sport Rod- SP3205 must be used.

A The approved piston must retain all its manufactured dimensions and weight. The JE and Manley pistons must maintain a 2.50" pin length. Wiseco pistons must maintain a 3.00" pin length. Additional gas porting of any type is not permitted. All rings must be installed, working and of magnetic steel. Stainless, z-gap, gapless, or Dykes type rings are not permitted. No portion of piston may protrude above the top of the block. The minimum ring thickness permitted is as follows: Compression rings .043" Oil ring assembly 3mm.

B Only magnetic steel non-coated piston pins maintaining a minimum diameter of .927" inch are permitted. They must be contained by bushings only (no bearings of any type). Full floating pins are permitted. Wrist pins may not be coated.

C Piston pin holes must be in a fixed location in the piston and connecting rods.

D Only two-piece insert style connecting rod bearings are permitted.

E The approved rod must retain all of its manufactured dimensions and weight. Only normal engine balancing and the use of after-market bolts and nuts are permitted. No de-burring, de-flashing, polishing, grinding or lightening is permitted. Rod length must be 5.700".

F. Minimum weight for piston, pin, ring, bearing and rod assembly is 1168 grams.

20E- 5.5.4 OIL PAN – Dry sumps, external oil pumps or tanks or accu-sump systems are not permitted. The Canton 11-196, **Moroso 21333** steel pan or any pre-approved existing aluminum oil pan may be used. Oil coolers are permitted. Only OEM in the pan magnetic steel type oil pumps are permitted. No pumps of any type may be used in the evacuation systems.

20E-5.6 HEADS – The Dart 10024266 cylinder head casting must be used. The casting part number must be purchased as completely produced by Dart, custom ordering of partial production/finishing is not permitted. The Dart casting is produced with, and must maintain a 60cc combustion chamber, a 2.02" intake valve and a 1.60" exhaust valve. Machining the valve guide bosses for seals and machining the gasket surfaces is permitted. The addition of screw-in studs, guide plates, valve spring seats, valve seals, poly-locks or jam-nuts is permitted.

Coolant lines are permitted on the front/rear ends of the heads. Coolant lines are not permitted on the side of the head. Max Intake port volume is 177cc. Max Exhaust port volume is 71cc. Head gasket surface milling tolerance for SK Modified® is 0.00" to 0.050" from true 23.00 degrees of stock valve position. The Intake to pin measurement must be no less than 6.050". No other machining or modifications of any kind are permitted. The ports/runners, combustion chamber, the valve angle and location must remain as produced by Dart. The EGR port may be blocked off at the intake gasket area only, by use of a metal shim on one surface of the gasket. The exterior of the casting may be painted. A maximum of 2 intake mounting holes may have HeliCoils. Intake and exhaust mounting holes may not be added or relocated. Holes must take standard dimension bolts.

VALVES- The Manley intake valve 11596 (111 grams), Manley intake valve 11864 (114 grams), Manley exhaust valve 11543 (95 grams) or Manley exhaust valve 11863 (102 grams) must be used. Valve stems must have a minimum diameter of 11/32 inch. Valve lifter weight is 85 grams minimum. All parts must maintain production dimension and weight.

VALVE JOB- When cutting the valve seat angles, no stone or grinding marks are permitted above the bottom of the valve guide. All cutting in reference to the valve job must be centered off the centerline of the valve guide. Competition style multi-angle valve job is permitted. The bowl area must pass the 360 degree "ball" check (the appropriately sized ball must not fall into the guide area when rolling around on the valve stem). Intake is a .787" ball. Exhaust is a .531" ball. Surfaces and/or edges where the cutter or stone has touched must not be polished. No hand grinding or polishing is permitted on any part of the head.

VALVE SPRINGS & RETAINERS- OEM Stock type magnetic steel retainers that weigh a minimum of 30 grams (retainer only) must be used. Valve springs may be single or double springs but must be parallel wound. Barrel wound, conical wound springs, or beehive type springs are not permitted. Double springs must have a diameter between 1.450" and 1.437". Valve springs must have a height of 1.700" to 1.800". Retainer locks must be magnetic steel, and must be Machine 7 degree, Super 7 degree, or 10-degree types only.

20E- 5.7 CRANKSHAFT

- A The Scat Cast or Steel Crank 9-350-3480-5700, Callies Comp Star series crankshaft #SAF113-CM, or the Manley 190190 may be used. The main and rod journal sizes are .020" under for the main and .030" under for the rod journals. Stroke must be 3.480". If you are currently converting an existing SK Engine over to the SK Spec Engine, you may use your existing GM cast or forged steel crankshaft, and it must weigh a minimum of 50 pounds and must be 3.480" to 3.495" in stroke. You must contact the NLWS Tech Staff to notify them of your intent to run this pre-existing crankshaft.
- B Small journal or Honda pin crankshafts are not permitted.
- C Machining or polishing of the crankshaft counterweights is not permitted. Normal standard engine balancing is the only acceptable modification that can be performed on this component. No painting or Teflon coating. No capping of the counterweight holes. Crankshafts must maintain the manufacturer's dimensions.
- D Minimum crankshaft weight is 45 lbs. for the SCAT, Callies, or Manley crankshaft, and 50 lbs. for the old style SK pre-existing crankshaft.
- E The Power Bond PB1012-ss, ATI 917260 , 917320, or the BHJ CH-IBS-6-C harmonic balancer must be used.

20E-5.8.1 CAMSHAFT- K15 or P55 cast core camshafts must be used (Billet steel cores are not permitted). The maximum camshaft bearing journal size is 1.875" (475mm). Camshaft may not exceed .550" +/- .005" lift at the valve with zero lash.

20E – 5.8.2 VALVE LIFTERS-

- A An 842" diameter magnetic solid steel valve lifter must be used. Roller tappets, ceramic valve lifters, tool steel solid lifters, mushroom valve lifters, and any type of mechanical assistance exerting a force to assist in closing the valve and/or push rod commonly known as rev-kits are not permitted.
- B Valve lifters can weigh no less than 85 grams.

20E- 5.8.3 ROCKER ARMS- Aluminum or stainless stud mounted roller rocker arms are permitted. 7/16" studs

may be used. Steel 5/16" x .080" minimum wall push rods must be used. Chevrolet must run 1.5 ratio rockers. Stud-girdles are permitted, aftermarket shaft rocker systems are not permitted. Competition Cams rocker part number 1604 will be permitted.

20E- 5.9 INTAKE MANIFOLD– A second generation Edelbrock 7101 intake manifold must be used. There are no modifications or alterations permitted to the intake manifold. No porting, polishing, acid dipping, deburring, de-flashing, abrasive cleaning, internal painting, milling, cutting, drilling holes, enlarging bolt holes, matching of ports, or welding. An NLWS supplied intake manifold must fit your engine complete with stock gaskets. All bolt holes must be in alignment and same size as stock. Coolant lines are only approved from the water neck to the back side of heads. The maximum thickness allowed for the Intake gasket is .064". Note: NLWS Officials reserve the right to swap competitors intake manifolds as part of their routine post-race tech process.

20E- 5.10.2 CARBURETOR SPACER –

The Big Haus USA 002 spacer must be used. One gasket per side, maximum gasket thickness of .075" permitted. The spacer may not be modified in any way. Additional openings for the induction of air is not permitted. Carb and spacer mounting hardware must be solid and must not permit air to pass through or by.

20E- 15 FUEL SPECIFICATIONS – The only approved fuel is Sunoco Supreme. Sunoco Supreme is available at The New London Waterford Speedbowl..

- A Icing or cooling of the fuel system is not permitted in the paddock, pit or racing area.
- B Gasoline may be tested and certified at any event through the application of various chemical analyses as considered appropriate by NLWS Officials. Gasoline may be checked before, during and after the racing events.
- C Nothing may be placed in the fuel line other than a standard fuel filter. The use of any type of fuel catalyst or other fuel-altering devices is prohibited.

20E- 9 ENGINE EXHAUST SYSTEM-

A SK Spec Engine must use the following headers:

Flowrite: Troyer 3025, CD 3035, Spafco 3055, Raceworks 3045

Kooks: Troyer NLWS1048, CD NLWS1438, Spafco NLWS1348, Raceworks NLWS1253

Beyea Performance: AMSST-23S1-SK

- B Headers must remain as manufactured, no modifications may be made to the headers.
- C The exhaust header flange must mount directly to the cylinder head with no spacers between the flange and the cylinder head. Header flange thickness may not be altered.
- D Inserts are not permitted in any part of the header or collector. Only one (1) collector allowed per side.
- E Turn-downs must be used after the mufflers, on each side. The turn-downs must be installed so that hot exhaust, engine debris, or engine flames are aimed at the ground (from pointing straight down to less than 90 degrees to horizon).
- F Kooks R35-30-10 or R35-35-10, the Flowrite FR-300 or FR-3500, or the Beyea Performance MUF3.5-SK mufflers must be used. The Muffler must be 3.5" on the inlet and outlet. Mufflers must be removable for inspection.

G Thermal wrap is not permitted anywhere on exhaust system.

H Only one muffler and exhaust pipe allowed per side. Exhaust system subject to approval by NLWS Officials.

I. Interior coatings are permitted.

NOTE: The life expectancy for all mufflers are two years. All owners are responsible to make sure their mufflers are in proper working order. If found not to be, the muffler will be deemed illegal (i.e., missing one or more of the internal baffles).

20E- 10 ENGINE DRIVE TRAIN – FLYWHEEL AND CLUTCH – SPEC ENGINE-

The Quarter Master 298108 or 298158, Tilton 51-2106 02 51-2136, 7-1/4" two disc V-Drive, with an SFI rated 153 tooth steel OEM type ring gear/flexplate that weighs a minimum of 4.1 pounds may be used with the SK Spec Engine. Optional stock type clutch rule: A Stock OEM dimension 153 tooth steel flywheel and 10" steel clutch and pressure plate may be used. OEM type steel pressure plate and steel disc only. Solid type disc

only, no paddle or button type discs. Minimum diameter 10" clutch and pressure plate. Drilling or lightening of any part is not permitted. Steel bolts only. Flat surface machining allowed only on the face of the flywheel, any cutting on the back side of the flywheel will deem the part illegal. Spec Engine flywheels must weigh a minimum of 9 lbs. (without bolts) and be one of the following part numbers:

10,000 RPM 1019-9.5

Magnus MRPBF-95

Ram 851

20E- 5.10 CARBURETOR – A Holley two-barrel model 4412 carburetor must be used. Only Holley replacement or service parts can be used in any carburetor rework. Carburetors and/or carburetor components machined from billet materials are not permitted. All parts must be a Holley manufactured part for the 4412 model. Polishing, grinding, resizing, or reshaping of any part or orifice is not permitted. The body, base plate, metering block, and bowl must be a standard Holley 4412 part, HP parts are not permitted. OEM type gaskets, jets and power valve must be used. The diameter of every hole in carburetor must pass the standard NASCAR

/NLWS pin and tooling gauges as part of our routine tech process

1. Body of carburetor and metering block: No polishing, grinding, or reshaping of any part. Drilling of additional holes or plugging holes is not permitted.
2. The choke may be removed, but all screw holes must be permanently sealed.
3. Choke Horn: Choke horn may not be removed.
4. Boosters: Boosters may not be changed. Size or shape must not be altered. Height must remain standard.
5. Venturi: Venturi area must not be altered in any manner. Casting ring must not be removed.
6. Alterations to allow additional air to be picked up below the opening of the venturi such as altered gaskets, base plates and drilling holes into the carburetor will not be permitted.
7. Base Plate: Base plate must not be altered in shape or size.

8. Butterflies: The stock Holley 4412 or Stainless Steel Holly part #346 butterflies must be used. They may not be thinned or tapered. The Butterflies must remain as manufactured and must maintain the Holley production tolerance thickness of .0438" to .0398". Idle holes may be drilled in butterflies. Screw ends may be cut even with shaft, but screw heads must remain standard.
9. Throttle Shaft: Shaft must remain standard and must not be thinned or cut in any manner.

20E- 5.12.1 CARBURETOR AIR FILTER / AIR FILTER HOUSING

- A. Only a round dry type paper air filter element maintaining a minimum 12 inches and maximum 14 inches diameter will be permitted. The air filter element must maintain a minimum of 1½" inches, maximum five (5) inches in height. All air must be filtered through the element. A nylon pre-filter may be used.
- B. Only a round metal filter housing will be permitted. The top and bottom of the air filter housing must be solid with no holes. A maximum of one (1) inch lip will be permitted from the air filter element to the outer edge of the air filter housing top and bottom. The air filter housing carburetor mounting ring must have only one (1) round hole a minimum of five (5) inches in diameter. It is permissible to attach a shield to the front area of the air filter housing up to a maximum of one half of the air filter circumference. The shield must not be higher than the height of the air filter element. The air filter housing metal top and bottom must be of the same diameter. The air filter housing must be centered side to side and set level on the carburetor. No air induction, ducts, baffles, tubes, funnels or anything else which may control the air entering inside of, or between the air filter and carburetor. No plastic air filter housings or parts.
- C. The bottom of the air filter element must measure within 2-1/2 inches of the carburetor's top flange. A spacer may be used between the carburetor and the air cleaner so long as this specification is not exceeded.
- D. No portion of the hood may be higher than the bottom of the air cleaner. You may not compete without the air filter, air filter housing or hood in place.

20E- 6.1 IGNITION SYSTEM – NASCAR approved ignition system must be used.

- A. Electronic distributors are permitted. All electronic distributors must be in stock type housings, have stock type controls and modules, be equipped with a magnetic pickup, be gear driven, and be mounted in the stock location. Billet distributor housings are permitted.
- B. Single or dual point camshaft driven distributors are permitted.
- C. Only one (1) ignition coil is permitted and must be mounted on engine side of the firewall.
- D. Electronic firing module amplifier box is not permitted.
- E. Computerized, multi-coil, dual electronic firing module box or crank trigger systems are not permitted. Magnetos are not permitted. All ignition systems are subject to approval by NLWS Officials.
- F. Adjustable timing controls are not permitted.

G. Retard or ignition delay devices will not be permitted.

H. Only MSD 8727CT or 8728 External RPM limiters may be used. The violet wire must be cut back flush to the unit's housing, with the green and the white wires run directly to the coil negative, mounted on the engine side of the firewall in plain view.

I. Accessories to regulate the power supply are not permitted.

J. The tachometer wire must run from the distributor to the tachometer along the #8 dash bar separate from any other wires and in unobstructed view for inspection. The tachometer wire must be isolated from any other wires, connections, or devices. The entire length of the tachometer wire must be visible from distributor to the gauge.

K. The Vacuum advance unit may be replaced with a manual non-electronic timing adjuster that does not extend more than two inches beyond the distributor housing.

20E- 6.3 ALTERNATOR – A functioning 12-volt single alternator system is optional.

20E- 6.4 STARTER – A stock type starter must be used. The starter must be in stock position and operative at all times.

20E- 6.5 BATTERY – One (1) 12-volt Gel or Glass Mat type battery with a minimum weight of 17 lbs. is mandatory. The battery must be located between the frame rails under the hood or the floor of the car. If located under the floor, the battery must be completely encased, if located under the hood the battery must have a suitable cover. The battery must not be forward of the radiator or rear of the rear end housing of the car. The battery location must be acceptable to NLWS Officials.

20E- 6.5.1 Thompson Speedway Sunoco Modifieds: Thompson Speedway Sunoco Modifieds utilizing the PASS/ACT Sealed 604 Crate Engines are allowed to compete. All motors MUST be sealed by LCM Race Engines in order to compete. No other GM 604 Crate Engines will be allowed to compete. All Thompson Speedway Sunoco Modifieds will follow all rules contained within the Thompson Speedway Sunoco Modified Rule Book related to the LCM Race Engines 604 Crate engine with the following exceptions.

1. The minimum weight at all times will be 2,645 pounds.

20E- 6.7.1 RADIOS

A. The in-vehicle radio must be analog only and must not be capable of transmitting or receiving in a digitized, encrypted, or scrambled format as determined by NLWS /NASCAR. Keypad style and/or password protected radios will not be permitted. Scanning and/or channel hopping transmissions to or from the in-vehicle radio will not be permitted. All transmissions to and from the in-vehicle radio must be in the 450.000MHz-470.000MHz UHF range. The in-vehicle radio is not permitted to transmit or receive any type of telemetry (data) signal or information other than audio communications and must remain independent from any electronic system in the vehicle. Teams will not be permitted to rebroadcast transmissions to or from the in-vehicle radio at any time during an Event. It is strongly recommended that all in-vehicle radio frequencies be licensed for use by the Federal Communications Commission (FCC) and meet all applicable regulations and guidelines.

B. Only one (1) NLWS / NASCAR-approved, two-way radio and one (1) radio push to talk button will be permitted. It is not permitted to have any frequency of any Competitor installed in the radio at any time. The vehicle is permitted only one (1), approved radio wiring harness.

C. At all times during practice(s), qualifying and the Race the spotter must have radio communications with the

driver and must monitor the NLWS Race Control frequency. Spotters must be in the designated spotter location at all times during competition.

D. The radio frequency being used will be made available to NLWS Officials.

E. Driver to driver radio communications will not be permitted.

20E- 6.7.2 SPOTTERS – Spotters are mandatory. Every car must have a spotter monitoring NLWS race control by way of scanner or radio, located in front of NLWS Race Control tower with radio communication to their car. Cars that do not follow directives from Race Control via their spotter may be black flagged and removed from the event, and the spotter suspended from competition.

Waddell Communications www.waddellcommunications.com 860-573-8821

20E- 6.7.3 TRANSPONDERS – Transponders are required on the cars at all times. See the NLWS General Rules for locating transponders properly. Any car not registering a transponder signal during practice may be black-flagged to be made aware of their scoring transponders failure and is required to remedy it before proceeding further in the event.

Mylaps America

www.mylaps.com

32 Highlands Parkway Suite 104

Smyrna, GA 30082

Tel 678-816-4000

20E- 7 ENGINE COOLING SYSTEM – Only Water or NLWS approved coolants or additives may be used in the cooling systems. Ethylene Glycol or Propylene Glycol coolants are not permitted.

20E- 7.1 WATER PUMP

A. A stock OEM type pump must be used. Electric pumps are not permitted.

B. Any serpentine, cog or V-belt pulley system is permitted.

20E- 8 ENGINE OIL SPECIFICATIONS – The use of combustion enhancing oils or additives is not permitted.

20E- 10 ENGINE DRIVE TRAIN – FLYWHEEL AND CLUTCH – The Quarter Master 298108 or 298158, Tilton 51-2106 02 51-2136, 7-1/4" two disc V-Drive, with an SFI rated 153 tooth steel OEM type ring gear/flexplate that weighs a minimum of 4.1 pounds may be used in with the SK Spec Engine. Optional stock type clutch rule: A Stock OEM dimension 153 tooth steel flywheel and 10.5" steel clutch and pressure plate may be used. OEM type steel pressure plate and steel disc only. Solid type disc only, no paddle or button type discs. Minimum 10.5" clutch and pressure plate. Drilling or lightening of any part is not permitted. Steel bolts only. Flat surface machining allowed only on the face of the flywheel, any cutting on the back side of the flywheel will deem the part illegal. The following weights are the minimum allowed for each part:

Flywheel only (no bolts) – Non-Spec Motor 12.5 LBS.

Pressure plate, Cover, & Solid Disc (no bolts) 16 LBS.

The steel solid disc (no bolts) must maintain a minimum weight of 2.5 pounds and a maximum weight of 3.8 pounds after the combined weight has been determined.

20E- 10.3 BELL HOUSING – Only a commercially manufactured magnetic steel bell housing may be used. The bell housing must enclose the flywheel 360 degrees with minimum 3/16" inch magnetic steel. Any

modifications you make to the bell housing must be done with 3/16" steel and welded in place (no bolt on pieces). A commercially manufactured bell housing (like the Quarter Master 008110440) with a bolt on bottom cover may be used. An opening no larger than 3 ½ x 4 inches may be used for throw out bearing access. This hole may be covered with sheet metal.

20E- 10.4 TRANSMISSION- The GM OEM production stock 3 or 4 speed transmission (top loader not permitted), Richmond two speed transmission (see approved part numbers below), or the Jerico 2SP (see approved part numbers below) transmission must be used.

- A. All transmissions must have a constant engagement of the input shaft with gear and countershaft with cluster gears.
- B. High gear must have a ratio of 1 to 1 and no other gear may have a ratio higher than 1.20 to 1.
- C. The shifter and all of its components must be aluminum or steel.
- D. Five-speed transmissions, with gears removed are not permitted. Quick change transmissions are not permitted.
- E. Automatic or semi-automatic transmissions are not permitted.
- F. Machining or lightening of any internal rotating or non-rotating parts including gears, shafts, and case are not permitted. Gun drilled transmission shafts are not permitted. Welding on any internal part is not permitted. Lightweight parts, machining, coatings, or special bearing upgrades are not permitted.
- G. Additional or different from OEM bearings other than the tail-shaft, which may have roller bearings, are not permitted.
- H. The transmission must be a "side shift" unit. Top shift transmissions are not permitted.

GM OEM Transmission-

OEM Stock cast iron, aluminum or magnesium transmission housings, or the Magnus part number MRPSA-1009 housing is permitted. The OEM Stock transmission side cover must be used. Removal of first gear or replacement of first gear with a metal spacer, in 4-speed transmissions is permitted. All other forward and reverse gears must be in working order, and they must be operational from inside the driver's compartment. Only OEM type, steel, angle cut forward gears are permitted. OEM gear ratios must be used. Lightweight parts, machining, coatings, or special bearing upgrades are not permitted.

Richmond Two Speed-

Modification of the dog-ring and slider (high gear only) in Richmond 2-speed transmissions is permitted. The following Richmond 2-speed transmission part numbers are the only approved Richmond part numbers: 7020010X, 7020026X, 7027010X, 7027026X, the X representing Richmond's ratios letter designator. The following Richmond produced low gear ratios are the only approved ratio for use in the Richmond 2-speed transmission: 1.2250, 1.3391, 1.4588, 1.5956, 1.7442. Lightweight parts, machining, coatings, or special bearing upgrades are not permitted.

Jerico 2SP-

The Jerico oval track 2speed transmission (part # 2SP, base model) as produced by Jerico is permitted. The Jerico 2 speed transmission may be run, with only the following "Low Gear" options allowed: 1.2250 to 1.7100, and "High Gear" must be 1:1. No modifications or options are allowed to the base Jerico 2SP.

The addition of any optional parts (other than base model supplied / needed), and/or any lightweight parts, machining, coatings, or special bearing upgrades are not permitted.

20E- 10.6 REAR AXLE

- A. Full floating magnetic steel double splined rear axles must be used.
- B. All axles must be a minimum of 7.00 pounds, and a minimum of 1.115 outer diameter.
- C. Only magnetic steel axles, bearings, and axle housings are permitted.
- D. Only one-piece, magnetic steel axles will be permitted. The axle splines must be straight cut, not crowned. Crown type axle splines will not be permitted.
- E. Cambered rear axle housings or other cambered components will not be permitted. A tolerance of 1½ degrees of camber (positive or negative) will be permitted.
- F. Only aluminum or steel drive plates, the same thickness on the left and right side will be permitted. The drive flange splines must be straight cut, not crowned.
- G. Only 10" ring gear full size spools are permitted. No posi-traction, limited slip, Detroit lockers, or any type of ratcheting differential is permitted.
- H. Thermal dispersant coatings are not permitted.

GEAR RULE – Quick Change rears must use a 4.11/4.12 (8/33 teeth), 4.57 (7/32 teeth), or 4.86 (7/34 teeth) 10" diameter ring & pinion gear set.

The 4.12 ring & pinion QC rear may use gear sets 25 (20/22), 12 (26/29), 7 (23/26), 7A (21/24), 17 (26/30), 17A (24/28) or 8A (23/27).

The 4.57 ring & pinion QC rear may use gear sets 1 (21/21), 2 (27/28), 5 (24/25), 15A (21/22) or 15 (19/20).

The 4.86 ring & pinion QC rear must use gear set 1, tooth count of 21/21.

Straight rears may use **5.33** maximum to **4.86** minimum, 10" diameter ring & pinion. (Changed for NLWS)

20E- 10.8 TIRES – Hoosier Tire East of Manchester, CT is the sole tire supplier for the SK Modified Division.

The approved compounds are **Hoosier M20 Left Side Tire** ~~27/13-15 M450~~ and **Hoosier M30 Right Side Tire** ~~26/13-15 M30~~. All tires used at NLWS must be purchased at the track on race day. NLWS Officials may confiscate and/or impound tires at any time for inspection. The JTR Eagle PPM tire chemical tester will be set at a fixed level and will be strictly enforced throughout the 2026 season.

Each tire will carry a special bar coded serial number. The legibility of the bar code is the sole responsibility of the team.

Drivers that have non-inventoried tires on their car during qualifying or feature events will be penalized.

In the event a driver changes cars for qualifying or feature racing, their tire inventory must accompany them to the new car (EIRI).

The amount of extra tires allowed for longer distance feature events will be determined by NLWS Officials. If a tire cannot be identified, it will be considered illegal.

NLWS Officials may change or amend these rules at any time.

20E- 10.8.1 TIRES PHYSICAL REQUIREMENTS

A Minimum circumference of right rear tire @ 20 psi. is 84".

B Minimum Tire Pressures for all inspection purposes are ten (10) psi for both left side tires and fifteen (15) psi for both right side tires. Air may be added to the tires to achieve only the minimum tire pressures during inspections, per an NLWS provided tire pressure gauge.

NOTICE: A participant competing in any race at NLWS specifically agrees that he/she acknowledges it is illegal to soak or treat racing tires and that said soaking or treatment of racing tires is subject to suspension.

20E – 12.1 COIL SPRINGS – Only coil spring suspension will be permitted. The suspension and coil springs at all four (4) wheels must be active and permit suspension movement in compression and rebound. All downward chassis movement while the race vehicle is in competition must be limited only by the normal increasing stiffness of the springs or the bottoming of the chassis against the race track, whichever occurs first.

Any device or procedure that in the judgment of NLWS Officials attempts to detract from or compromise the above will not be permitted, including "coil-bind". Any type of chassis travel limiter, used in compression or rebound, will not be permitted. Front shocks must have a minimum of 2" of piston available for spring travel in compression. All coil springs must not be colder than ambient temperature.

A maximum of two full (360 degree) non-adjustable spring rubbers are permitted in the coil springs. Shock/Coil over boots or bags are not permitted.

Coil Over Springs:

- 1 Coil over springs must mount to the lower A-frames.
- 2 Strut bars will not be permitted for mounting of coil over front springs.
- 3 Coil over springs must be manufactured from one solid piece of heavy-duty magnetic round steel (flat or oval wire is not permitted) and must be constructed with both coil ends closed and ground. One inactive coil on each end of the coil spring is permitted.
- 4 Only one (1) spring per wheel will be permitted.
- 5 Coil springs may be coated but coating thickness and material must be acceptable to NLWS Officials.
- 6 All active coils of the spring must have the same coil spacing, same wire diameter, and same inside and outside diameter. The first and last coils may be different due to having closed and ground ends.
- 7 Progressive or digressive rate springs will not be permitted.
- 8 Front coil must be a minimum of 8" in free height and a minimum of 250 lbs. per inch rating. You may not use any type of device to alter the load on the front springs, other than the normal loading of the coil-over nut. Rear coil must be a minimum of 8" in free height.

20E – 12.2 SWAY BARS (ANTI-ROLL BARS) Front sway bar must be for the purpose of anti-roll only. The front sway bar must freely rotate in its mounts. The movement of the front sway bar arms must not be prevented or restricted beyond that of normal use as an anti-roll bar.

A Only magnetic steel front sway bars will be permitted.

A Rear sway bars (anti-roll bars) will not be permitted.

NLWS reserves the right to set and enforce a maximum sway bar spring rate.

20E- 12.3 COIL OVER SHOCKS –

The following shocks are permitted for competition in 2026:

JRI – 200-426 with piston # JRI14511778-A and 200-427 with piston # JRI14511778-A

Pro – AC series

QA-1 – 6Q Series (formerly 62 Series)

TFR-PL-DL005-1DG (Waterford Additional allowed shock)

Shocks will be disassembled and/or dyno'd for inspection and comparison.

The quantity and the thickness of factory supplied shims on the piston may be altered, all other components must remain as manufactured.

The piston shim stack and the shock oil are the only components you may change, every other component must be as factory produced by the shock manufacturer.

All shocks must be single adjustable, available to all competitors "race ready" with a published price of **\$500** or less ready to race, less any separate coil-over kits.

All shocks subject to NLWS Officials' approval.

20E- 12.5 SPINDLES, WHEEL BEARINGS and HUBS – Front spindles must be linked to frame utilizing two individual tethers per spindle. All tethers and their installation must be acceptable to NLWS Officials. Low drag components (excluding seals) are not permitted. The use of oil filled hubs, oiled bearings, low friction bearings, non-steel bearings, coated or polished spindles, bearings or races will not be permitted. Two standard steel wheel bearings, a wheel bearing seal, a torque nut and a standard nut locking mechanism are the only components permitted on each spindle/hub assembly.

E. Oil filling of any spindles, wheel bearings or hubs is not permitted.

20E- 12.6 TRACK WIDTH REQUIREMENTS

A. All cars must maintain the following track width requirements. A minimum front and rear track width of 82 inches and a maximum track width of 83-3/4 inches will be permitted. The track width will be determined by measuring the left outside wheel (rim) bead surface to the right outside wheel (rim) bead surface at spindle height.

B. Aluminum or steel spacers will be permitted to utilize the maximum allowable track width. Spacers must be acceptable to NLWS Officials.

20E- 12.8.2 GROUND CLEARANCE REQUIREMENTS – The frame rail and sheet metal ground clearance will be a minimum of two (2) inches. All ground clearance requirements will be measured with the driver in the car.

Officials will check ground clearance / ride height before and after feature events.

The nose panel, frame rail and door panel must maintain a 2" minimum ground clearance / ride height at all times.

20E- 14.1 BRAKE COMPONENTS

A. Four wheel disc brakes are mandatory. Only magnetic cast iron or cast steel round circular rotors permitted. Only metal brake calipers will be permitted. Drilled, slotted or grooved rotors are not permitted. Only factory dust cleanouts are permitted. Dust cleanouts should not exceed .038 in depth. If the dust cleanout exceeds .038 in depth, the rotor may be deemed illegal. The brake rotors must be bolted directly to the hubs. Floating brake rotors will not be permitted.

B. Only Single stage master cylinders are permitted. All brake components are subject to NLWS Officials approval.

20E- 14.2 – BRAKE COOLING Electric blowers are not permitted for cooling purposes in brake duct systems. Additionally, electric blowers are not permitted anywhere on the car for cooling (i.e. brakes, rear end, etc.).

20E- 15 FUEL SPECIFICATIONS – The only approved fuel for any SK engine is Sunoco Supreme. Sunoco Supreme is available at the Ne.

A. Icing or cooling of the fuel system is not permitted in the paddock, pit or racing area.

B. Gasoline may be tested and certified at any event through the application of various chemical analyses as considered appropriate by NLWS Officials. Gasoline may be checked before, during and after the racing events.

C. Nothing may be placed in the fuel line other than a standard fuel filter. The use of any type of fuel catalyst or other fuel-altering devices is prohibited.

20E – 18 ROLL BARS – (8) – (A) The door bars (#9 A & B), on both the left and right sides, must have a minimum of four (4) bars equally spaced from top to bottom that must be welded horizontally between the vertical uprights of the main roll bar (#1) and the front roll bar legs (#2 A & B). The top door bar on each side must maintain a minimum vertical height of 15-1/2 inches from the top of the main frame rails to its centerline and match up with the intersection of the dash panel bar (#8) at the roll bar legs (#2A & #2B) at the front and the intersection of the horizontal shoulder bar (#7) at the main roll bar (#1) at the rear. All door bars must be convex in shape. The door bars (#9 A & B) must have a minimum of six (6) vertical supports per side with two

(2) equally spaced between each door bar. These supports must be made from a minimum of 1-3/4 inches by 0.090 inch wall thickness magnetic steel seamless round tubing (not numbered but shown in the left side view of diagram #3). Right side door bars must cover a minimum of 25 inches of door length and may be either four (4) horizontal bars with six (6) vertical studs or two (2) horizontal bars and two (2) bars configured in an X design. If the X design is used, a vertical bar must connect through the center of the X from the top horizontal bar to the frame.

(B) A 13 gage (0.0897 inch thick) magnetic steel anti-intrusion plate(s) must be securely welded to the outside of the left side door bars. The anti-intrusion plate(s) must fill the area between the horizontal centerlines of the top and bottom door bars, and vertical centerlines of main roll bar (#1), and the left front roll bar leg (#2A). The plate(s) must be formed to match the curvature of the door bars. Plate(s) welded between the vertical upright bars should be as large as possible. All plate(s) must have the corners welded with one (1) inch of weld followed by a maximum of three (3) inches of surface not welded and followed again by a minimum one (1) inch weld. To facilitate emergency removal of the left side door bars (#9A), the anti-intrusion plate must have six (6), 2-1/8 inch diameter holes cut in the anti-intrusion plate, with three (3) holes forward of the front vertical supports and three (3) holes rearward of the rear vertical supports in the following locations: The upper two (2) holes must be centered vertically between the left side door bars (#9A-1&2), at an on-center distance of three

(3) inches from the center of the front vertical support and the rear vertical support. The middle two (2) holes must be centered vertically between the left side door bars (#9A-2&3), at an on-center distance of three (3) inches from the center of the front vertical support and the rear vertical support. The lower two (2) holes must be centered vertically between the left side door bars (#9A-3&4), at an on-center distance of three (3) inches from the center of the front vertical support and the rear vertical support (see Diagram #2, in the rear pages of the rulebook).

(9) All cars must have a foot protection bar acceptable to NLWS Officials installed on the left side of the roll cage. The foot protection bar must be located at or in front of the pedal assembly, when viewed from the side and above. The foot protection bar must be completely welded to the left front roll bar leg (#2A) and extend forward and be completely welded to the main frame rail or front sub-frame.

It is recommended that you run two “ear” bars on the driver’s side, with two horizontal bars connecting them, to reduce the exposure of the drivers head area. These bars should be made with 1-3/4” DOM steel tubing. These bars may be plated, similar to the drivers door bars, for added protection in this area.

CONTINGENCIES- Contingency Sponsors are a valuable part of the NLWS program. Contingency stickers must be displayed for either product or monetary consideration. Each division will be notified as to what stickers are required to be eligible for contingency rewards. In particular, the decals must be mounted on the driver's side of the car in such a manner that they are clearly visible in a photograph. Contingency stickers must be used as supplied by NLWS. Alterations to the stickers are not permitted.

RECOMMENDED ENGINE BUILDER LIST

R.A.D. AUTO MACHINE 80 RAVENWOOD DR.

LUDLOW, MA 01056 Don Wood 413-583-4414

www.radautomachine.com

PERFORMANCE ENGINES 79 HAYES STREET

TORRINGTON, CT 06790 Billy Mathes 860-489-0363

PETTIT RACING ENGINES

44 OLD STATE ROAD UNIT 38 NEW MILFORD, CT 06776 Mike Pettit

860-354-3339

LARRY'S AUTO MACHINE AIRPORT IND. PARK

GROTON, CT 06340 Gary Espinosa 860-449-9112

www.larryspower.com

CARLQUIST COMPETITION ENGINES 98 FALLS AVE.

OAKVILLE, CT 06779 Bill Carlquist 860-247-0742

EAST COAST MACHINE

59 OLD BROADWAY NORTH HAVEN, CT 06473 Peter Chillemi 203-996-

8767

eastcoastmachine@yahoo.com

AUTO MACHINE LLC. 65 BARBER HILL ROAD

BROAD BROOK, CT 06016 Dave Miller 860-870-8811

ANDY'S AUTO MACHINE 48 LEWIS STREET

PLAINVILLE, CT 06062 Andy Krawiec 860-793-2455

andrewkrawiec@snet.net

SPECIALTY PERFORMANCE ENGINES 160 OLIVER ROAD

LEBANON, CT 06249 Brian Kowalshyn 860-917-3436

specialtyperformanceengines@hotmail.com